

Hybrid Pro Modular Counter 20

HPC-20

The Hybrid Pro™ Modular Counter 20 is a simple wood counter that is sophisticated in appearance and easy to assemble. It comes in four color options, and you can add an optional adhesive backed vinyl graphic to add a pop of color. This three-piece counter is easy to assemble and pack!



We are continually improving and modifying our product range and reserve the right to vary the specifications without prior notice. All dimensions and weights quoted are approximate and we accept no responsibility for variance. E&OE. See Graphic Templates for graphic bleed specifications

features and benefits:

- Sleek and stylish laminated wood counter
- Three piece assembly for quick set up
- Optional adhesive backed vinyl graphic
- Color options include dove grey, black, designer white and fusion maple
- Packs into OCH2 portable case

dimensions:

Hardware

Assembled unit:

29.53" w x 39.37" h x 23.23" d
750mm(w) x 1000mm(h) x 590(d)

Approximate Weight:
52lbs / 24 kg

Graphics

Refer to related graphic templates for more information Visit:

<https://www.theexhibitorshandbook.com/downloads/download-graphic-templates> or click here

Shipping

Packing case(s):
1 OCH2

Shipping dimensions:
OCH2:
(52" L x 29" H x 15" D)
1448mm(l) x 1449mm(h) x 838mm(d)

Approximate shipping weight:
87lbs / 40 kg

additional information:

Graphic material:

Printed vinyl front and back edge.

Panel Colors:



Dove
Grey



Black



Designer
White



Fusion
Maple

1 person assembly recommended:



This product may include the following materials for recycle: aluminum, select wood, fabric, cardboard, paper, steel, and plastics.

Included In Your Kit

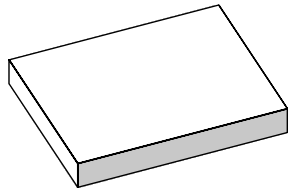

x1 COUNTER TOP

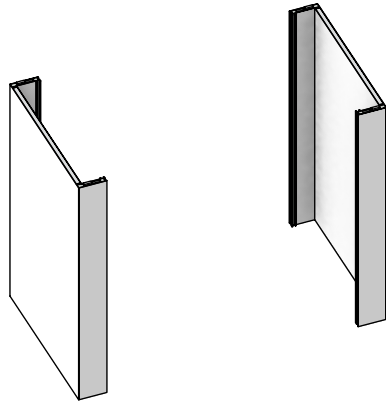

x2 LEG



7PC (SILVER) HEX KEY SET

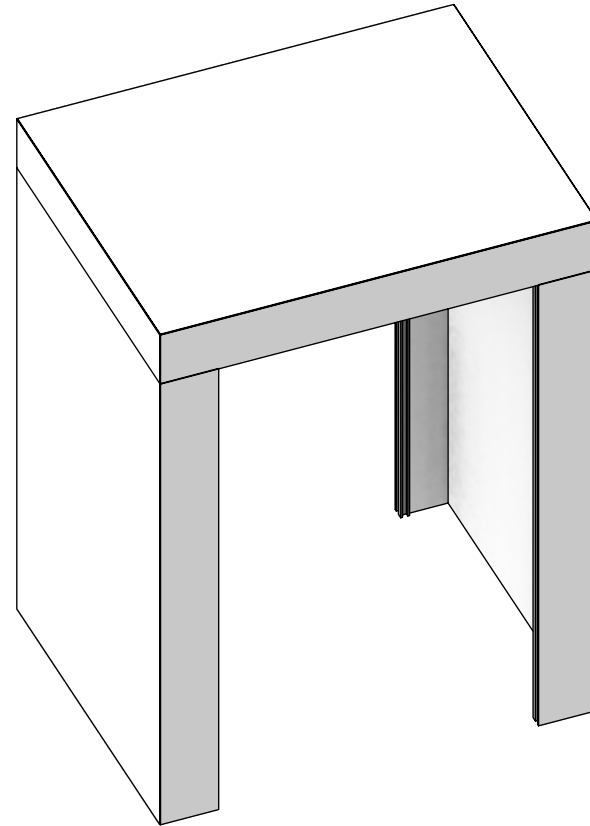

Hybrid Pro Modular Counter 20

1. Remove the top panels from case and lay it upside down on the floor, then lock each vertical side to the top as shown using the provided hex key. Be sure to match the colored dots for correct positions.

2. Once the legs are securely locked into place turn counter unit upright.

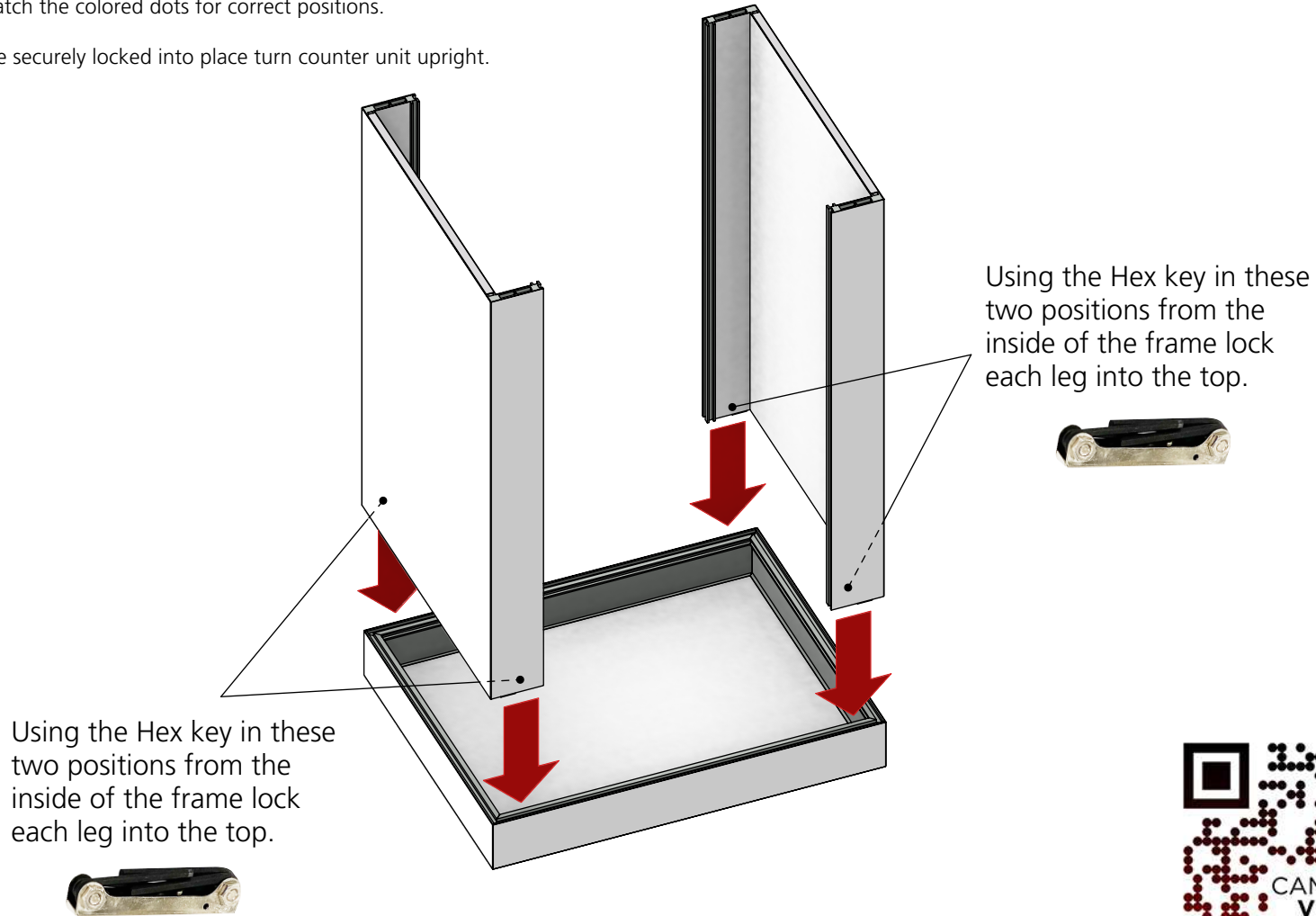

ASSEMBLY