

HD 100

Part Number: 170005 011 1M HD100

Weight Capacity.....750 lbs [340 kg]
 Standard RPM.....1 (Direction Control Switch Provided)
 Torque Output @ 1 RPM.....60 ft-lbs [81 Nm]
 Motor Draw.....0.46 A (50 W)
 Shipping Weight.....225 lbs [102 kg]
 Power Cord.....8ft [2.4m]

Not Rated For Outdoor Use

PERFORMANCE TIPS

- Keep The Unit Level
- Keep The Weight As Centered As Possible

FINISH

- Top = Powdercoat RAL 7040 Gray
- Base = RAL 7040 Gray Enamel

ELECTRICAL

- Motor = 110VAC, 60Hz, 0.46A
- Wire = 14GA Grounded Cord, 8' Long

OTHER

- Hardened Steel Gears
- Slewing Ring Bearing
- 11GA Steel Turntable Top
- 3/8" Steel Base And Support Plate

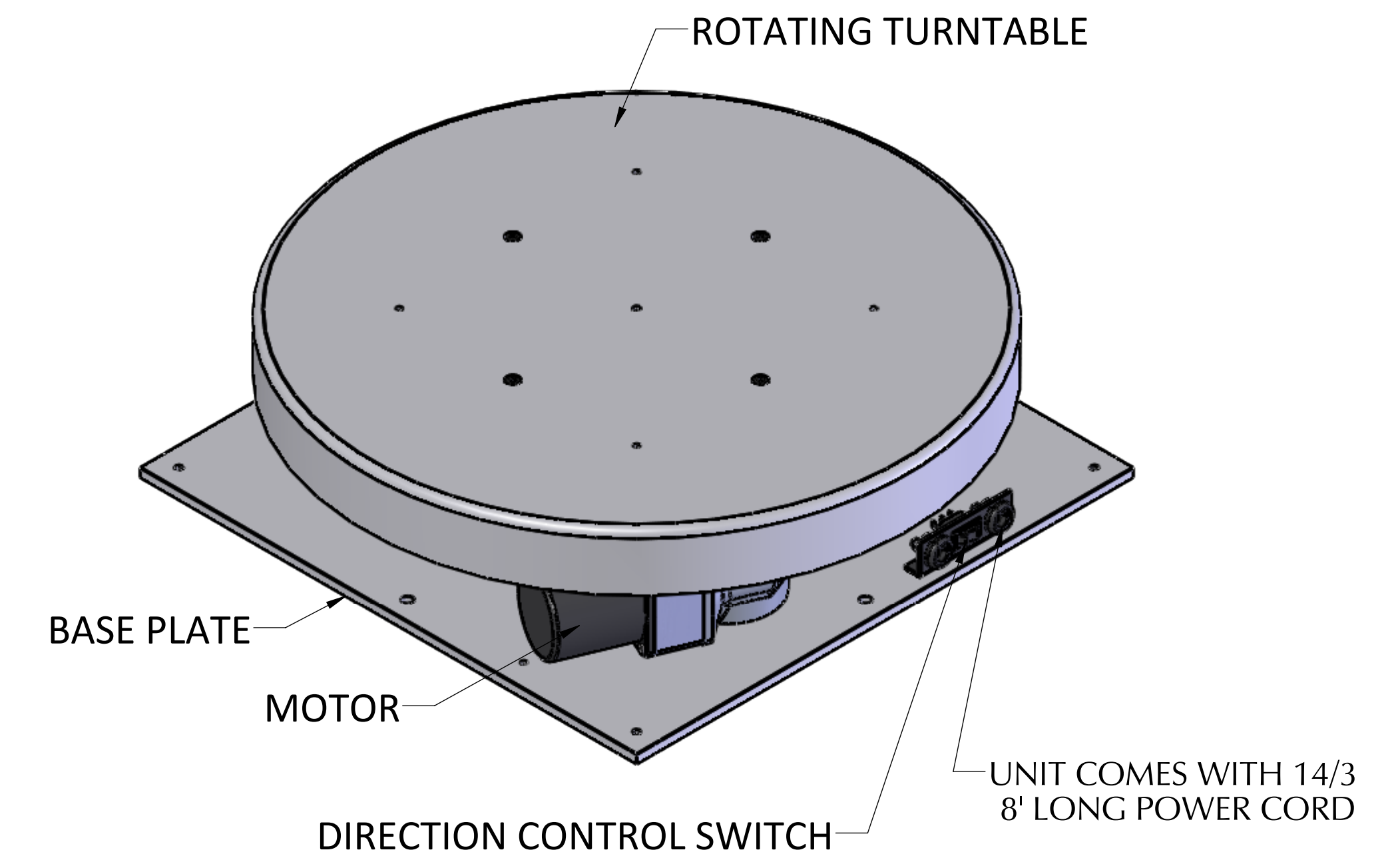
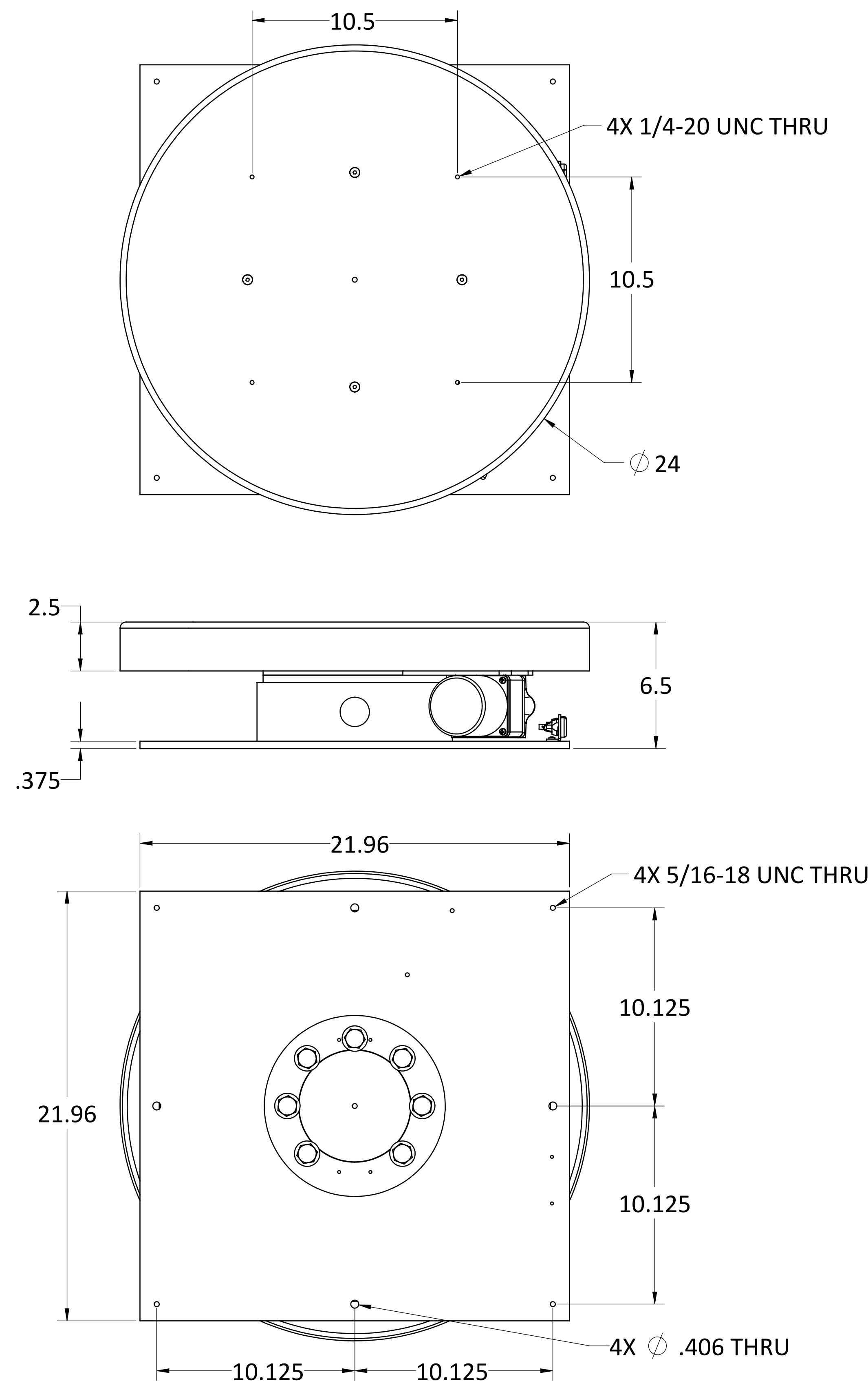

Vue-More powered by Dynapac Motion
 338 Hansen Ave., Salt Lake City, UT 84115
 Phone: 610-266-9600
 email: info@vuemore.com • www.vuemore.com