

# HD 201

Part Number: 170005 311 1M HD201

Weight Capacity.....1000 lbs [450 kg]  
 Standard RPM.....1 (Direction Control Switch Provided)  
 Torque Output @ 1 RPM.....60 ft-lbs [81 Nm]  
 Motor Draw.....0.46 A (50 W)  
 Shipping Weight.....235 lbs [107 kg]  
 Power Cord.....8ft [2.4m]  
 Rotating Electric Outlet Capacity.....15A (1.8kW)

Not Rated For Outdoor Use

**PERFORMANCE TIPS**

- Keep The Unit Level
- Keep The Weight As Centered As Possible

**FINISH**

- Top = Powdercoat RAL 7040 Gray
- Base = RAL 7040 Gray Enamel

**ELECTRICAL**

- Motor = 110VAC, 60Hz, 0.46A
- Wire = 14GA Grounded Cord, 8' Long

**OTHER**

- Hardened Steel Gears
- Slewing Ring Bearing
- 11GA Steel Turntable Top
- 3/8" Steel Base And Support Plate

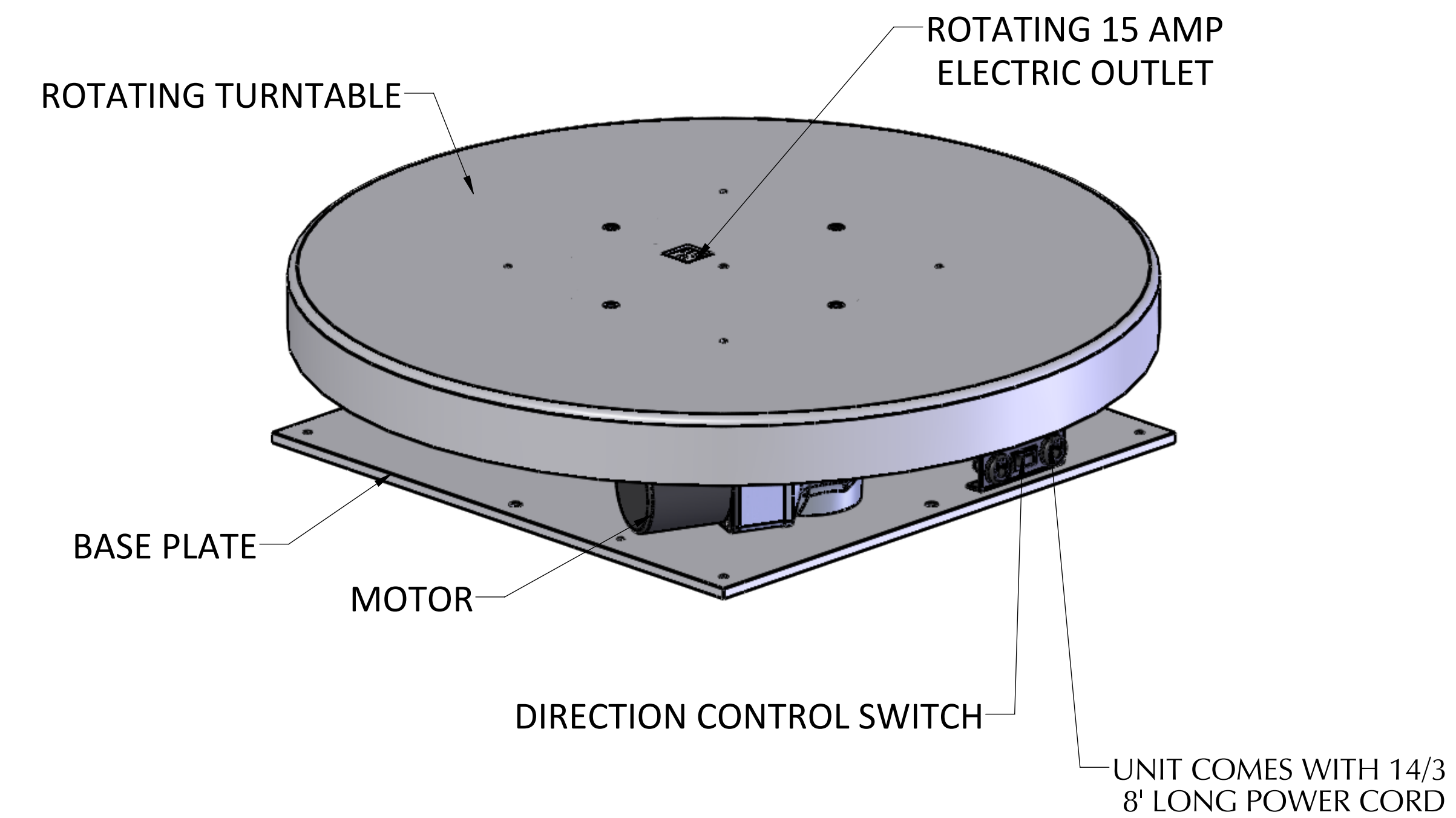
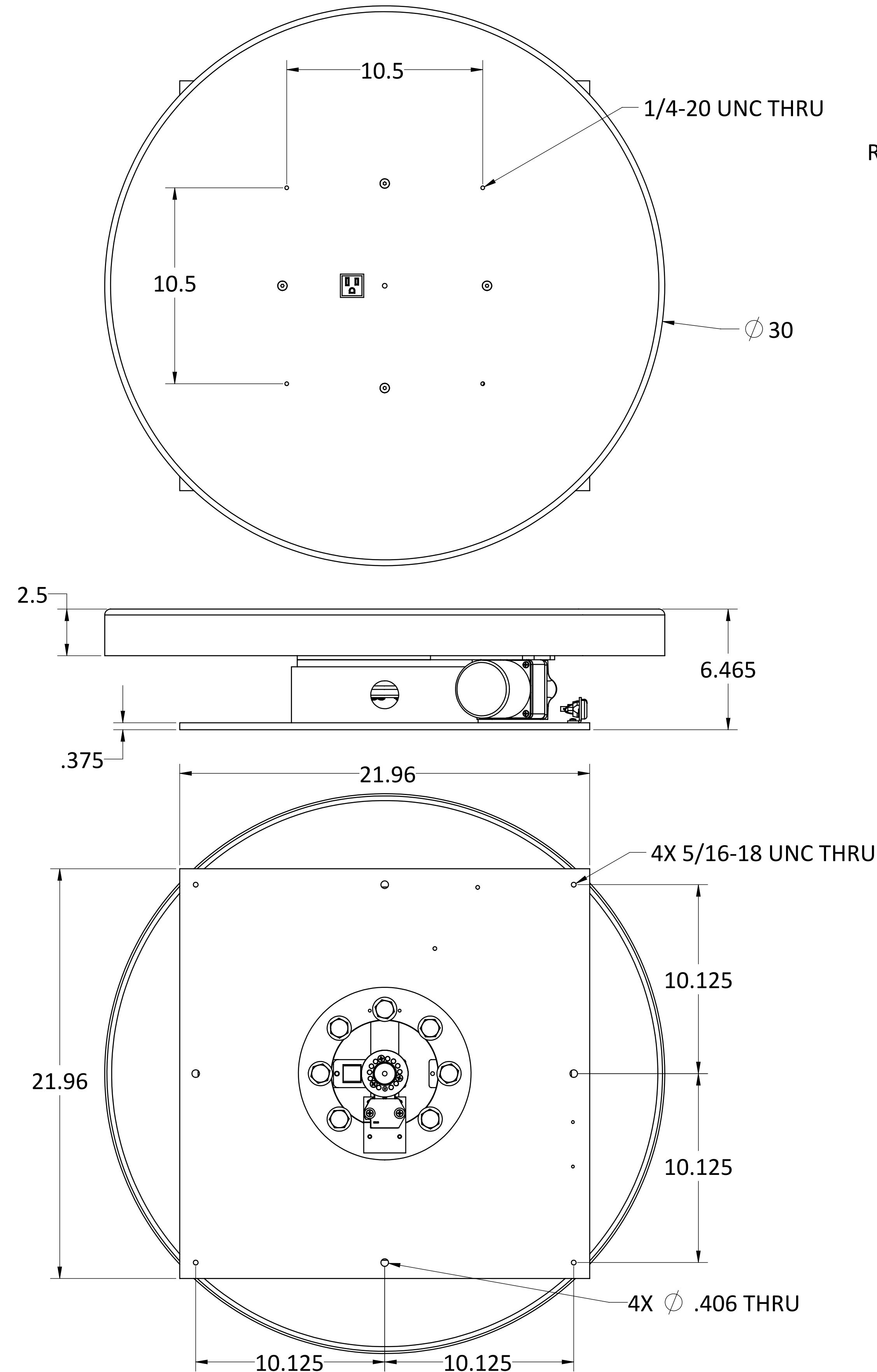

Vue-More powered by Dynapac Motion  
 338 Hansen Ave., Salt Lake City, UT 84115  
 Phone: 610-266-9600  
 email: info@vuemore.com • www.vuemore.com