

Model MB200 VS

(Floor/ Tabletop Installation)

Installation and Maintenance Instructions

Questions? Call 610-266-9600 for help

For ALL installations:

- Display or sign load MUST be balanced.
- Do NOT use stabilizer casters or wheels to support turntable.

Display or Sign mounted on TOP of Rotator:

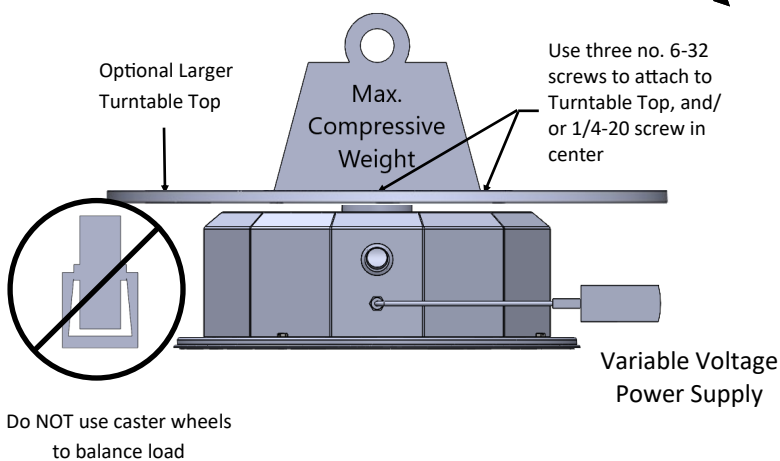

Model:	Max. Compressive Weight:
MB200 VS	200 lb

- Standard rotation is clockwise. Direction is set at factory.
- Larger diameter turntable top may be attached to rotator turntable.
- Load must be placed directly on turntable top.
- Weight MUST be balanced (add a counter-weight if needed).
- Keep unit level.
- Not for outdoor use.

WARNING! Do NOT hang weight from unit.

Hanging weight will cause unit to come apart and fall.

Maintenance:

No regular maintenance is required for this unit.



Vue-More
Turntables
Powered by Dynapac Motion





Phone: 610-266-9600
Email: info@vuemore.com
www.vuemore.com

Model MB200 VS

(Floor/ Tabletop Installation)

Electrical Connections

Questions? Call 610-266-9600 for help

⚠ WARNING	
	Disconnect power before servicing or installing. Do not touch any electrical components while unit is connected to power source.
	Keep hands clear while operating. Read installation and maintenance instructions prior to operation.

Unit without rotating wires/outlet:

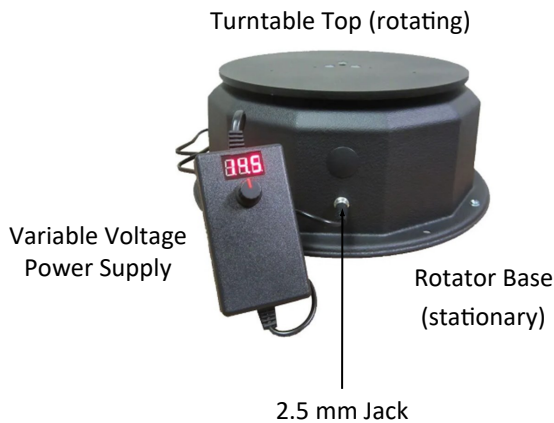

- No rotating electrical wires or outlet are available.
- Plug Variable Voltage Power Supply into 2.5 mm Jack on Rotator Base.
- Plug Variable Voltage Power Supply cord into wall outlet.
- Turn knob on Variable Voltage Power Supply to start rotating.

Model:	Motor power draw:
MB200 VS	24 W max

Limited Warranty:

The manufacturer warrants the enclosed unit, to the original purchaser only, against factory defects in material and workmanship for twelve months from date of purchase.

Should the unit prove defective or fails to operate properly in use during the warranty period specified above, the manufacturer will repair it or replace it without charge when returned to the factory, freight prepaid, by the original producer. This warranty will be considered void if the product is tampered with, altered, modified, improperly installed or serviced, or damaged through misuse, negligence, or accident. Labor provided by the customer to remove or replace the unit is not covered under this warranty. Warranty covers parts replacement only.

When the warranty is not applicable, the customer will be charged for the cost of repair plus shipping charges. Items damaged in shipping must be returned to the factory in its original container.

The manufacturer shall in no event be liable for inconvenience, or for incidental, consequential, contingent, or any other damages. This warranty is made in lieu of any other express warranty, and, except for the foregoing warranty, which is exclusive, there is no other warranty being made.



Vue-More
Turntables
Powered by Dynapac Motion



Phone: 610-266-9600
Email: info@vuemore.com
www.vuemore.com