

Formulate 20' Serpentine - Kit 4

FMLT-WSC20-04

Formulate™ is a collection of sophisticated, ergonomically designed exhibit booths. Formulate combines state-of-the-art zipper pillowcase dye-sublimated fabric coverings with advanced lightweight aluminum structures to provide unique design, functionality, and style. The excellence of the Formulate line of displays, hanging structures and products is simply unmatched. Stretch fabric graphics are hand-sewn, durable and dry-cleanable.



features and benefits:

- State-of-the-art 50mm aluminum tubing with heavy duty internal spigot connectors
- Hardware mounts for a medium sized monitor; max 36"/ 40 lbs
- Top and bottom printed infill panels on accent ladder
- Kit includes: one frame, one dye-sublimated zipper pillowcase graphic, monitor mount, side table, and two wheeled molded OCL and one OCH2 storage cases
- Lifetime hardware warranty against manufacturer defects

dimensions:

Hardware	Graphic
<p>Assembled unit: 226.0280"w x 93.1439"h x 32.9894"d</p> <p>Stand-off Monitor mount with side table: 36.3"w x 92.7"h x 28.75"d</p> <p>Table dimensions: 20.47"w x 11.81"d</p> <p>Approximate weight (includes graphic): 92 lbs / 41.7 kgs</p>	<p>Total visual area: 236.5"w x 92"h s-curve 6007mm(w) x 2337mm(h)</p> <p>Stand-off ladder total visual area: Top & bottom: 21"w x 17"h</p> <p>Please be sure to include a 2" bleed around the perimeter of dye-sublimated graphic and a 1/2" bleed around the perimeter of pvc stand-off graphic.</p>
<p>Shipping</p> <p>Shipping dimensions - ships in 3 cases: 2 OCL cases (each): 19"l x 19"w x 56"h 1 OCH2 case: 52"l x 30"w x 15"h</p> <p>Approximate shipping weight (with case): 162 lbs / 73.5 kgs</p>	<p>Refer to related graphic template for more information.</p> <p>Visit: www.exhibitors-handbook.com/graphic-templates</p>

additional information:

Graphic material: dye-sublimated zipper pillowcase fabric, 3mm white pvc

Monitor mount: max T.V. size is 36"/ 40 lbs

*Kit does not include monitor

Table colors:



silver

black

mahogany

natural



www.display-setup-animations.com

We are continually improving and modifying our product range and reserve the right to vary the specifications without prior notice. All dimensions and weights quoted are approximate and we accept no responsibility for variance. E&OE. See Graphic Templates for graphic bleed specifications.

Parts Included		
Part Label	Qty	Part Code
EXPANDING SPIGOT FOR 50MM TUBE	x14	ES-50
20' FABRIC GRAPHIC	x1	WSC20-01-G
INLINE CONNECTOR FOR 30MM TUBING	x3	TC-30-S
50MM CORNER TUBE	x4	WSC20-T1
300MM X 50MM TUBE	x2	WSC20-T2
R2736MM X 50MM TUBE	x4	WSC20-T3
R2736MM X 50MM CURVED TUBE WITH HOLE RIGHT SIDE	x2	WSC20-T3-HR
R2736MM X 50MM CURVED TUBE WITH HOLE LEFT SIDE	x2	WSC20-T3-HL
1093MM X 30MM TUBE	x6	WSC20-T4

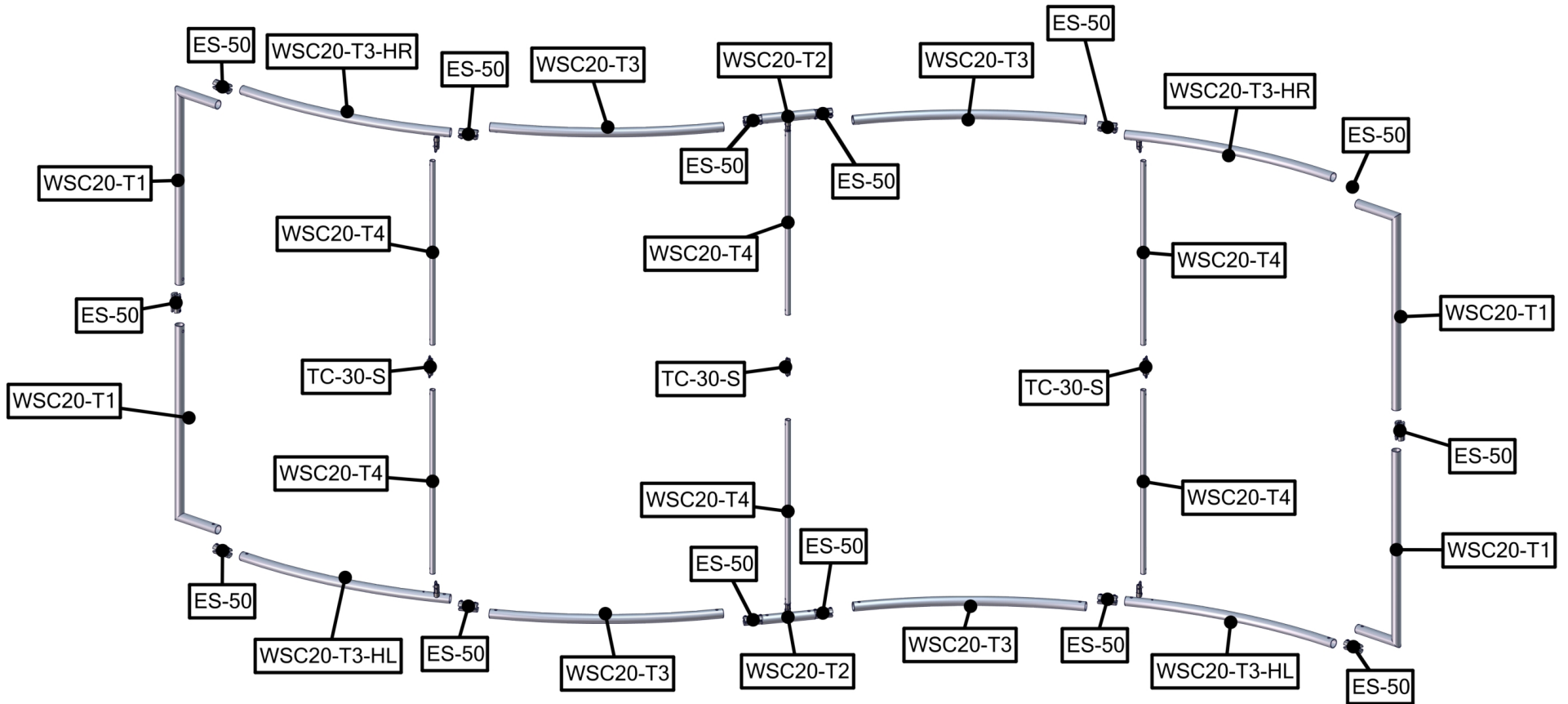

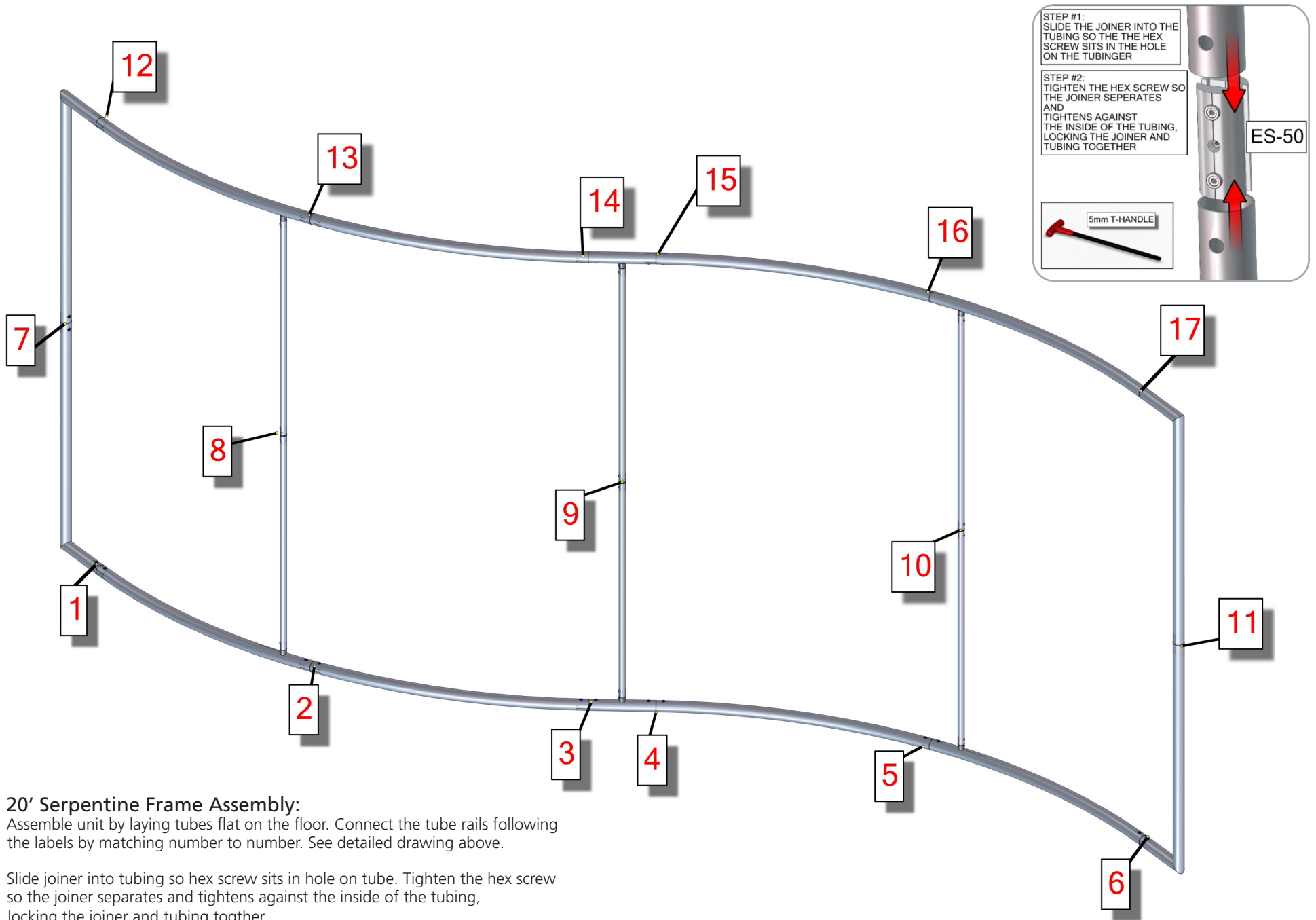

20' Serpentine Frame Assembly:

Assemble unit by laying tubes flat on the floor. Connect the tube rails following the labels by matching number to number. See detailed drawing above.

Slide joiner into tubing so hex screw sits in hole on tube. Tighten the hex screw so the joiner separates and tightens against the inside of the tubing, locking the joiner and tubing together.

At connection 8, 9 and 10, connect tubes by pressing snap on button, lining up holes and securing button in hole.

Parts Included		
Part Label	Qty	Part Code
30MM TUBE CLAMP	x2	ACC60
MEDIUM MONITOR BRACKET	x1	MM-MB
520 X 300 X 30 COUNTER	x1	CTWL03
SILVER ANODIZE FINISH 50MM TUBE CLAMP	x2	TC-30-50
30MM TUBE SECTION	x2	WL-T3
TOP SINTRA GRAPHICS	x2	WLLH-T-G
30MM TUBE SECTION	x1	WL-T13
30MM TUBE SECTION	x1	WL-T6
30MM TUBE SECTION	x1	WL-T7
RWL-T10	x1	RWL-T10

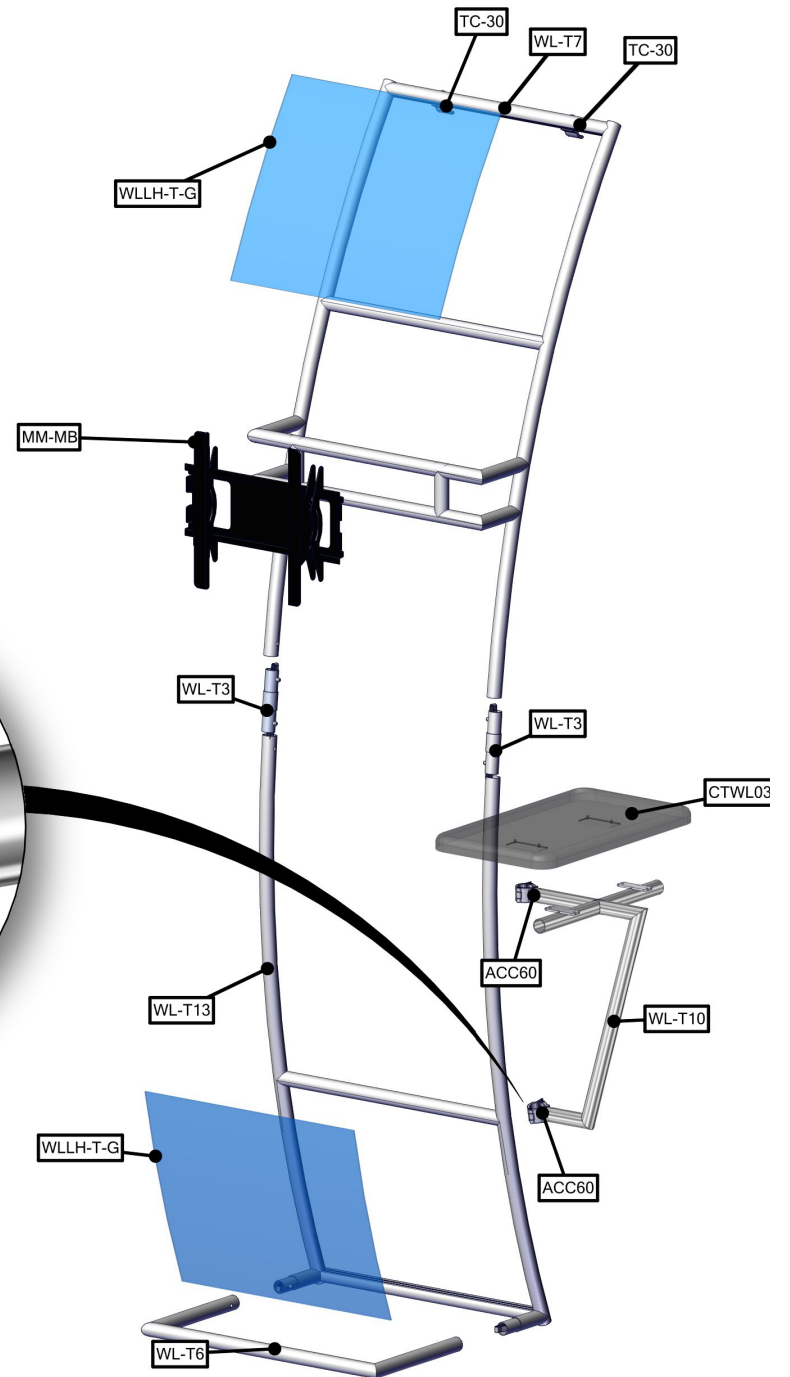
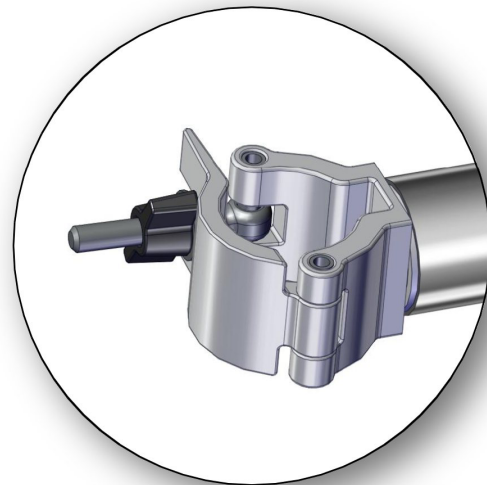

STEP 1: ASSEMBLE FRAME

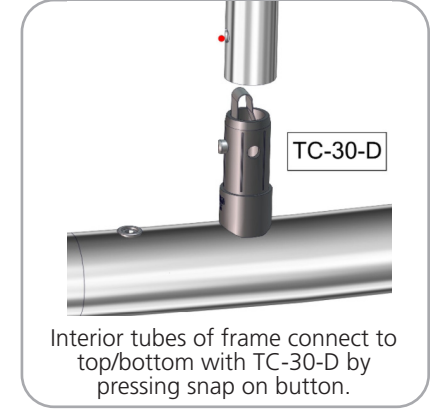
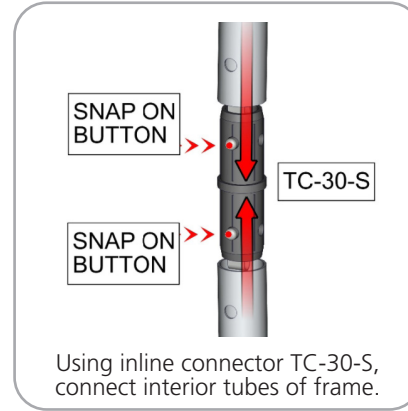
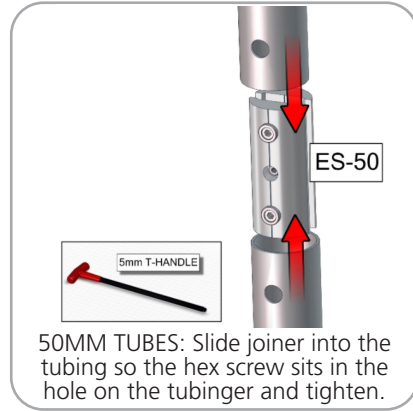
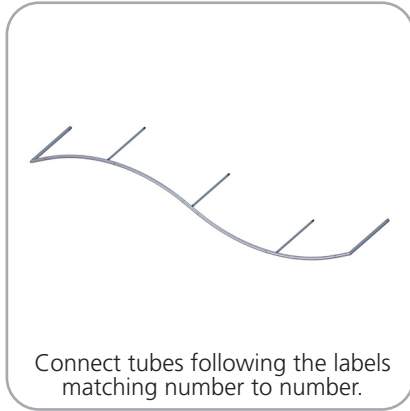

STEP 2: ATTACH GRAPHIC

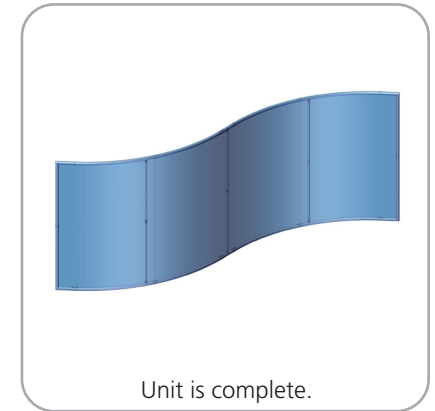
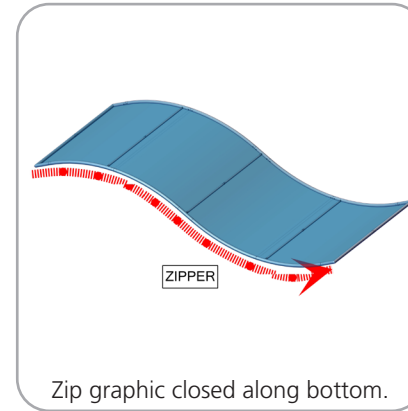
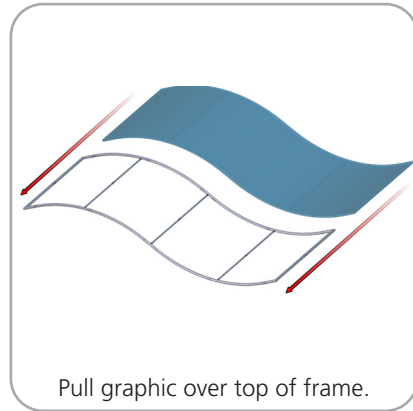
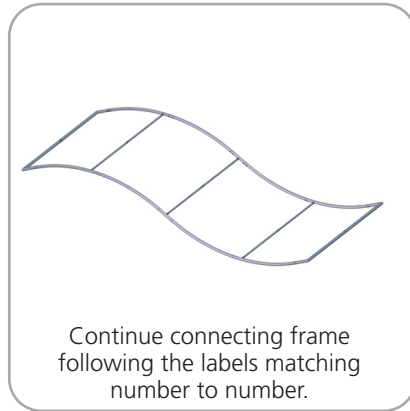

STEP 3: ASSEMBLE FRAME

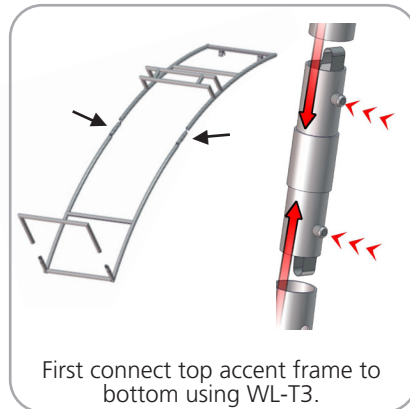

STEP 4: ATTACH TABLE

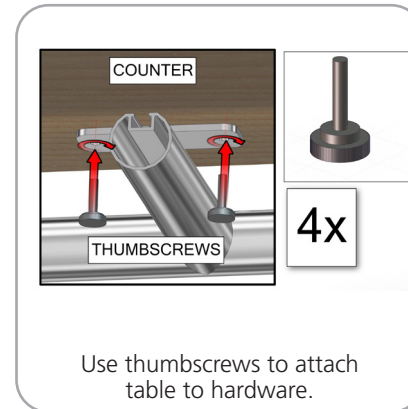

STEP 5: ATTACH TABLE TO ACCENT FRAME

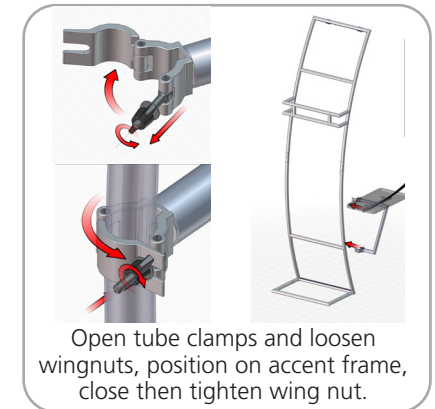

STEP 6: INSTALL MONITOR MOUNT

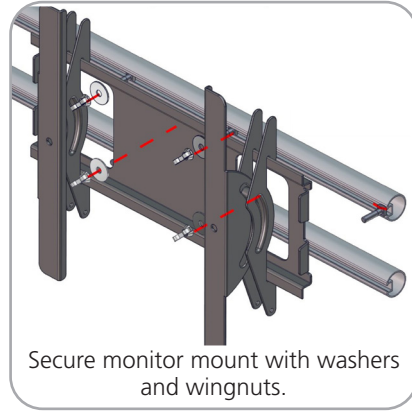
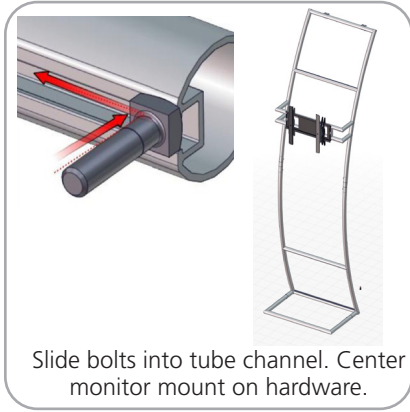

STEP 7: ATTACH GRAPHICS

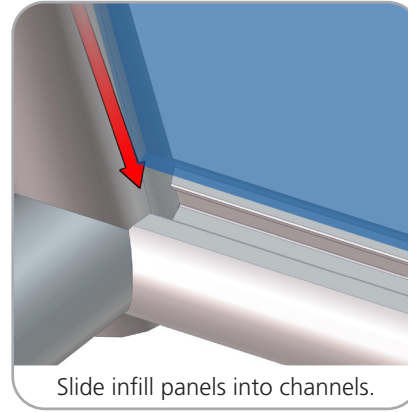

STEP 8: ATTACH TO BACKWALL WITH CLAMPS

