

# LINEAR 08

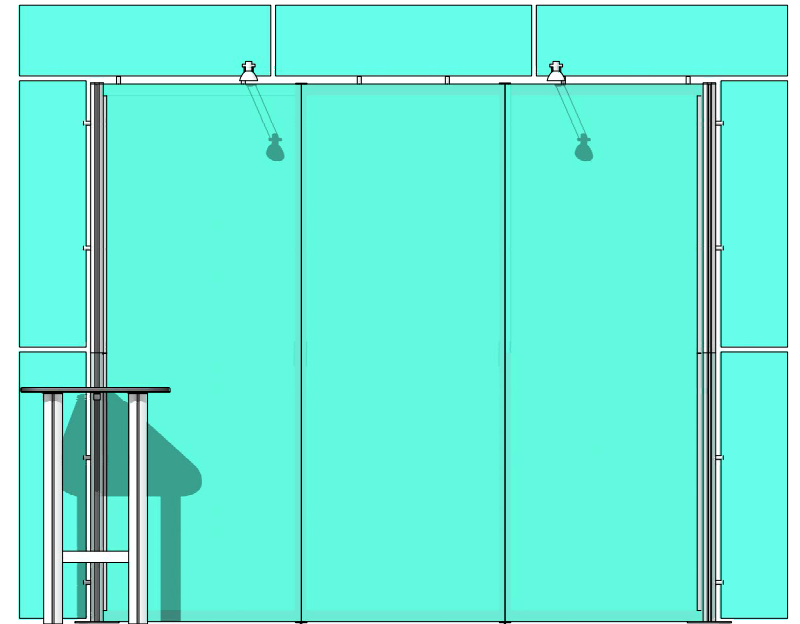

Code	#	Description
L3	3	HORIZONTAL GRAPHIC BAR
L4	2	VERTICAL GRAPHIC BAR WITH CENTER FOOT POST
L1	2	BOTTOM HALF UPRIGHT

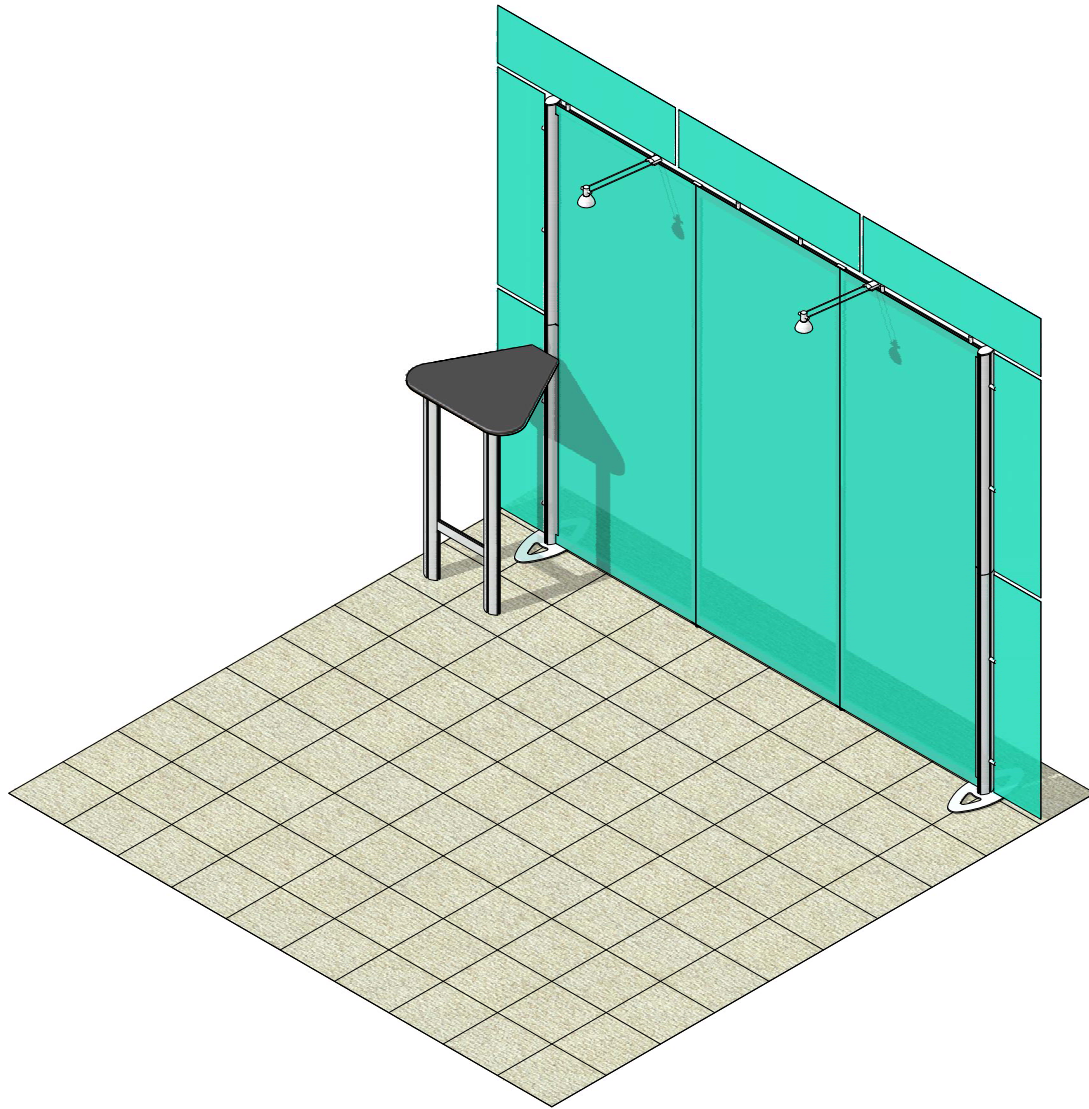
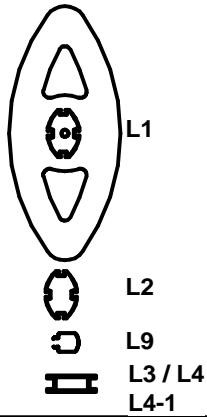
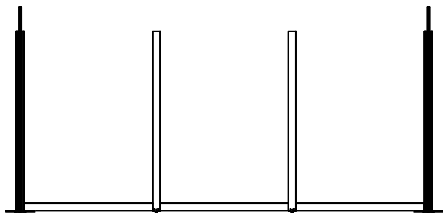
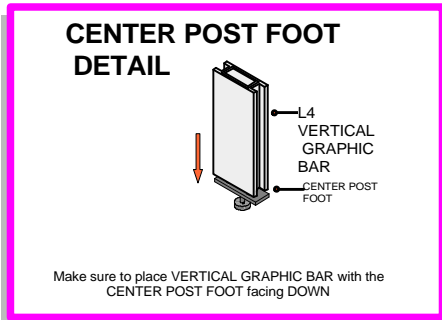
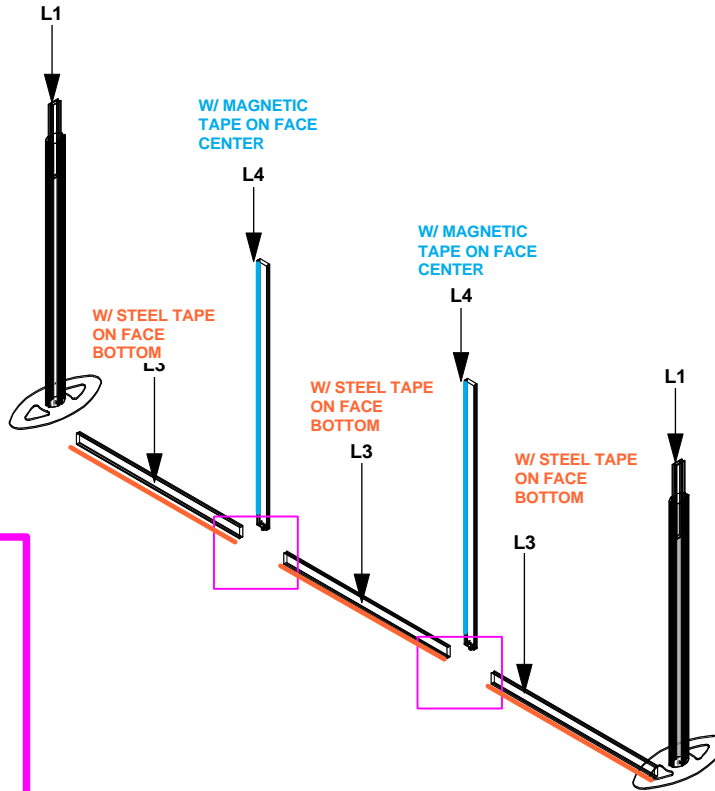
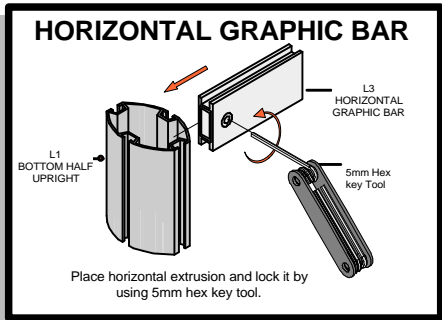
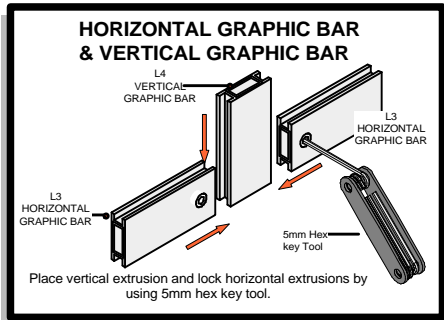

LINEAR

Code	#	Description
CORNER LOCK	1	CORNER LOCK
JOINER BAR	4	JOINER BAR

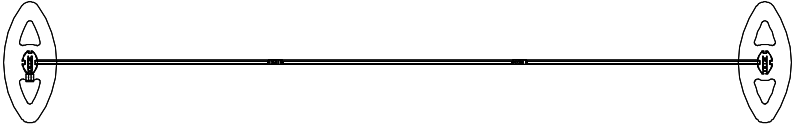

**CORNER LOCK DETAIL**

CORNER LOCK

Slide CORNER LOCK into front channel.

**JOINER BAR DETAIL**

SET SCREW

VERTICAL GRAPHIC BAR

Slide the JOINER BAR the tracks of one extrusion. Then push the two extrusions together.

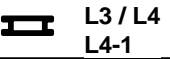
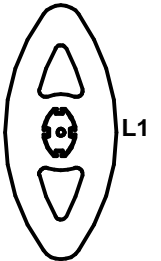
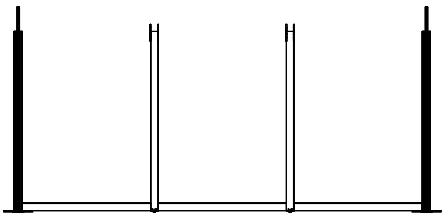
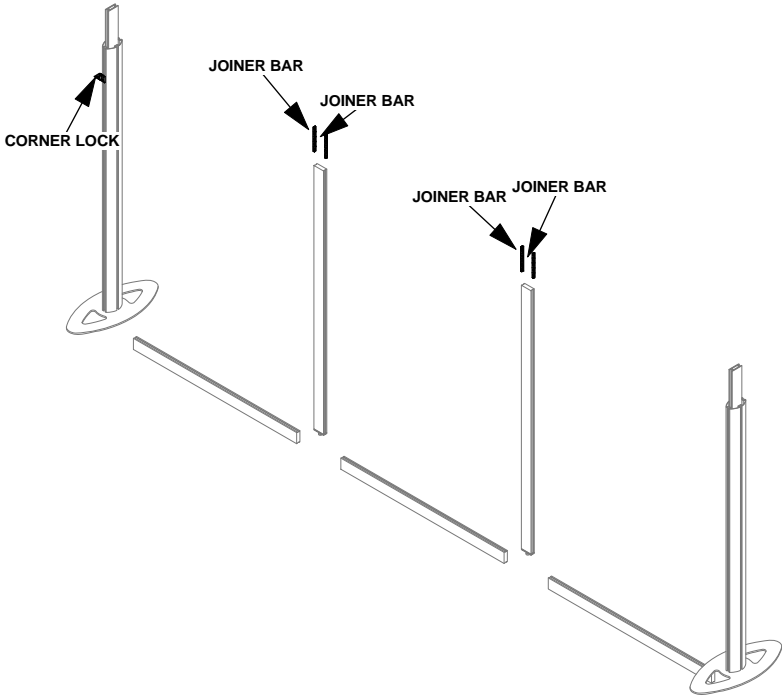

**LINEAR**

Code	#	Description
L2	2	TOP HALF UPRIGHT
L6	2	CAP
L3	3	HORIZONTAL GRAPHIC BAR
L4-1	2	VERTICAL GRAPHIC BAR
L9	4	GRAPHICS MOUNTING BAR
CPH C	2	CAP FOR VERTICAL GRAPHIC BAR

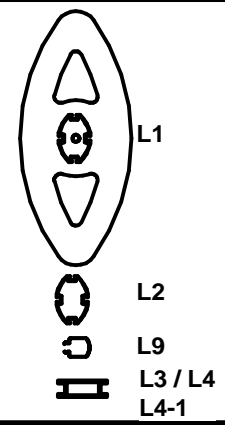
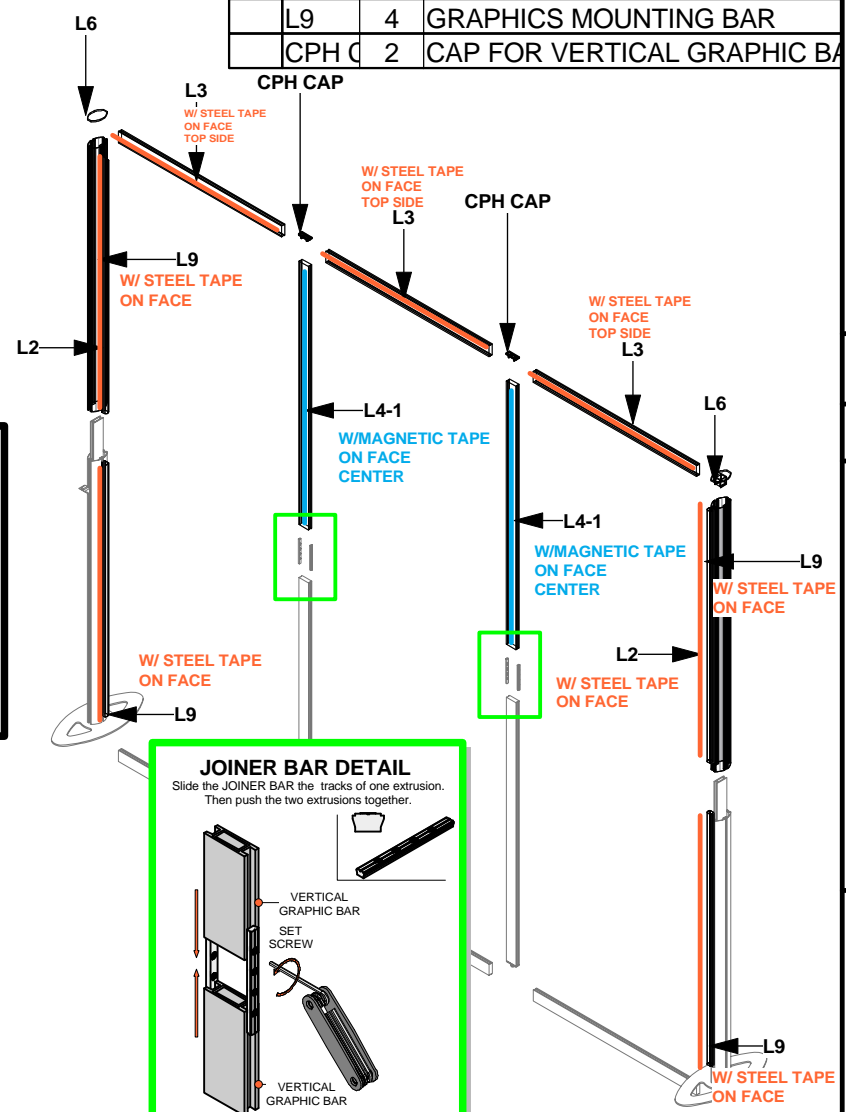
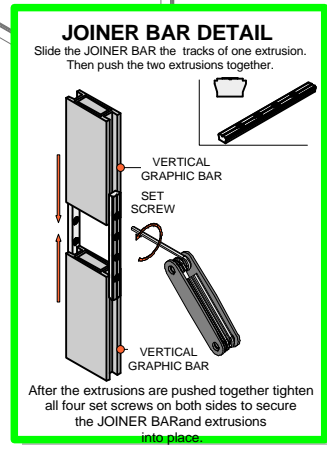
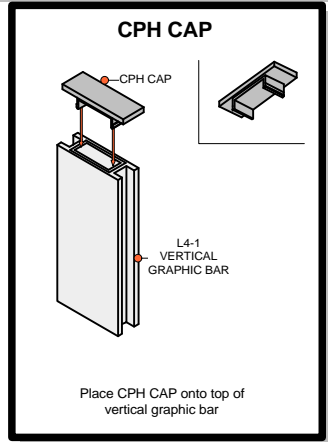
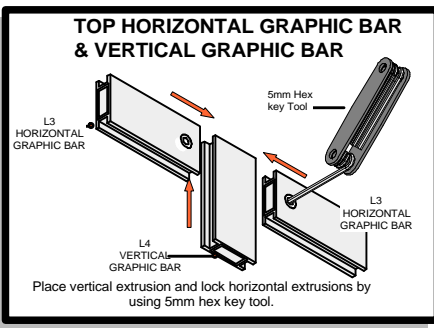
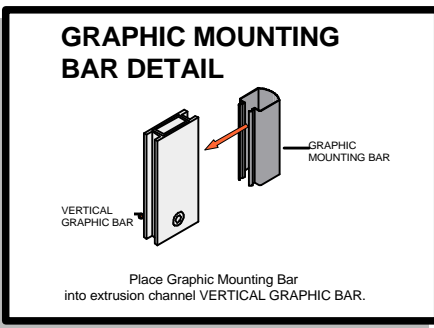
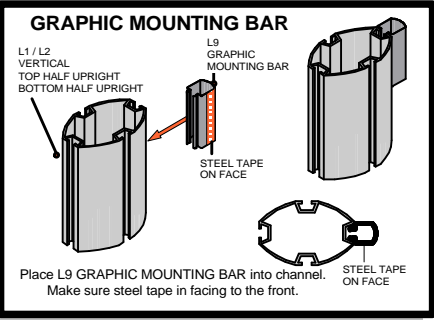
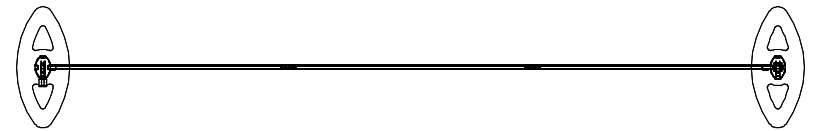

**LINEAR**

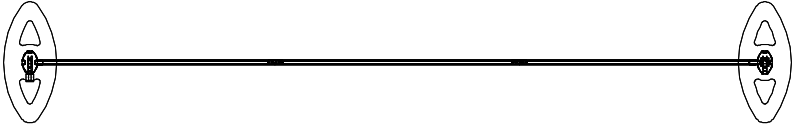

Code	#	Description
L5-2	1	GRAPHICS
L5-1	1	GRAPHICS
L5-3	1	GRAPHICS

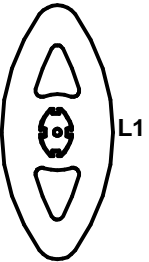
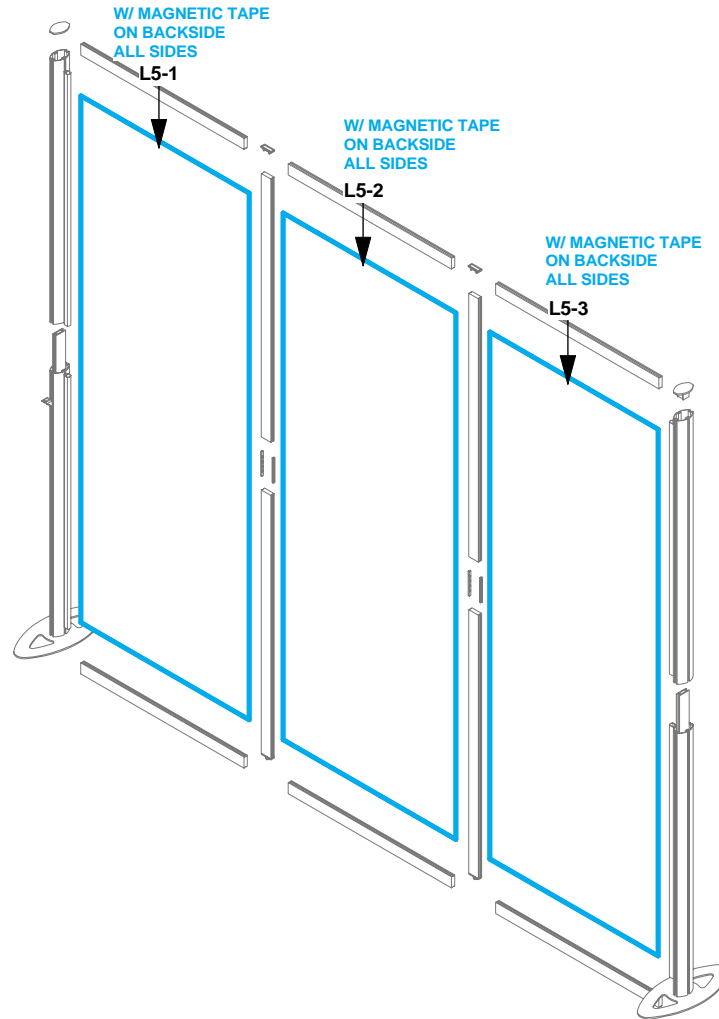
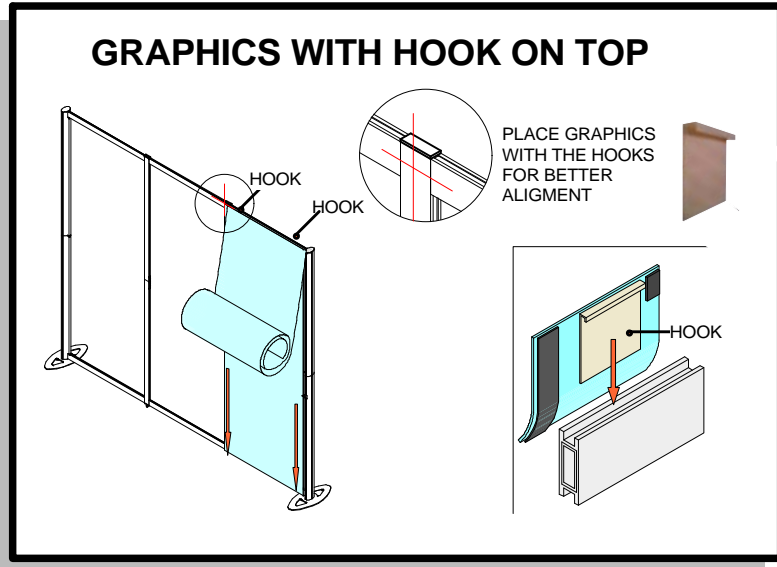

L1



L2



L9



L3 / L4

L4-1

LINEAR

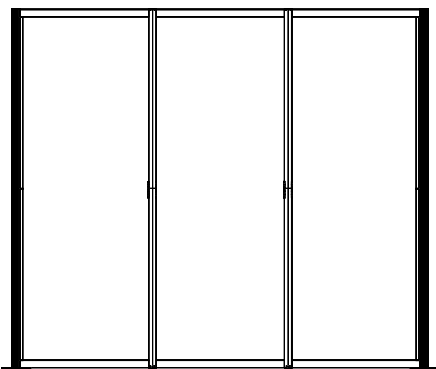

Code	#	Description
LV3 LIGHT	2	GREY SKINNY LIGHT WITH OSRAM TITAN 50W LA

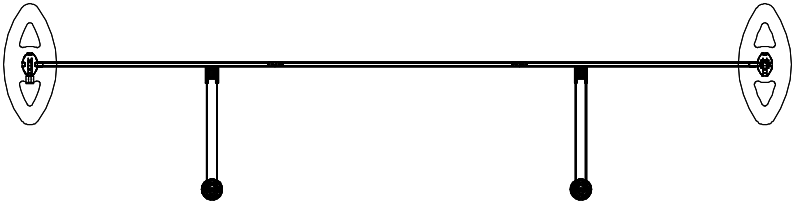

**LIGHT DETAIL**

Slide the light clip into the channel and then gently lower down. Then slide the LV3 Light onto the light clip.

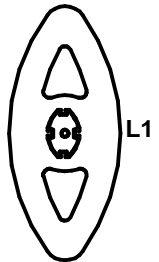
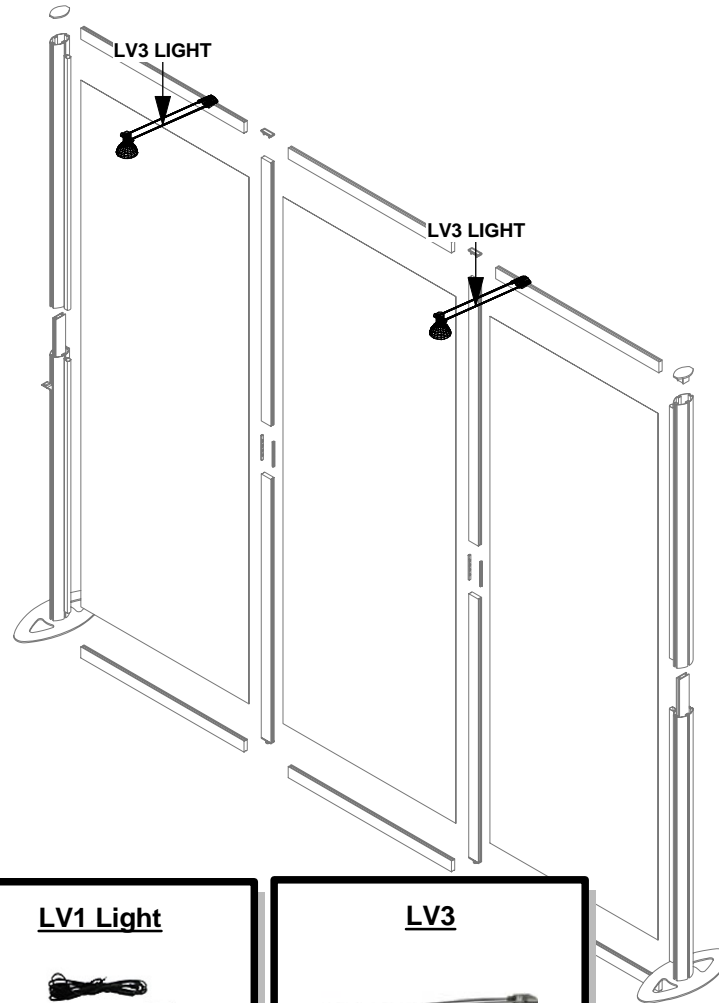

- L1
- L2
- L9
- L3 / L4
- L4-1

**LINEAR**

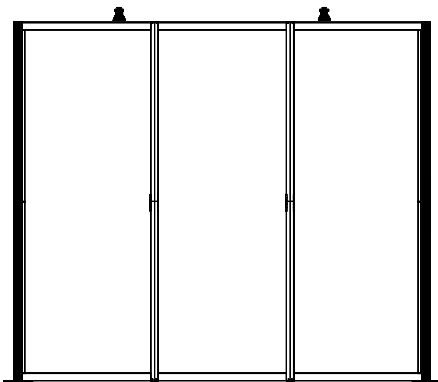



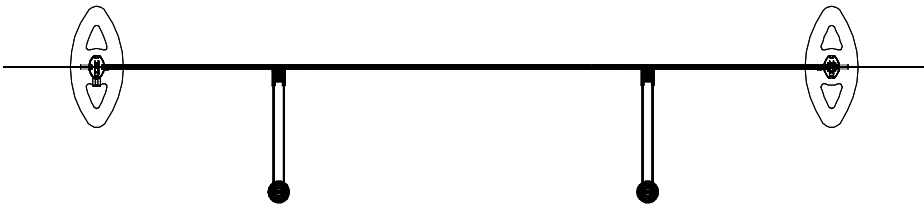

Code	#	Description
CKAPS	14	STANDOFFS
L11-5	1	GRAPHICS
L11-6	1	GRAPHICS
L11-7	1	GRAPHICS
L11-2	1	GRAPHICS
L11-1	1	GRAPHICS
L11-4	1	GRAPHICS
L11-3	1	GRAPHICS

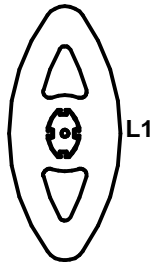

L1



L2



L9



L3 / L4



L4-1

LINEAR

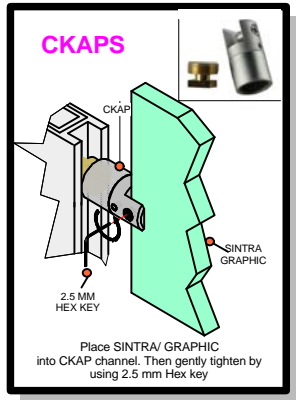
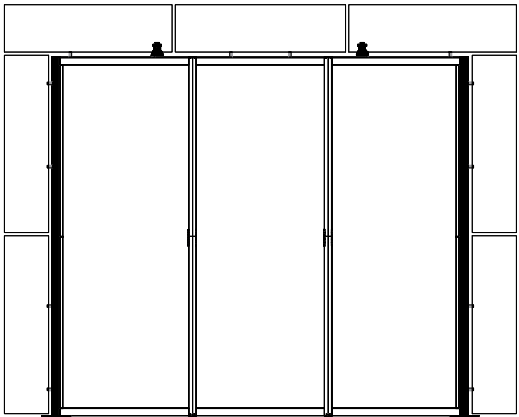
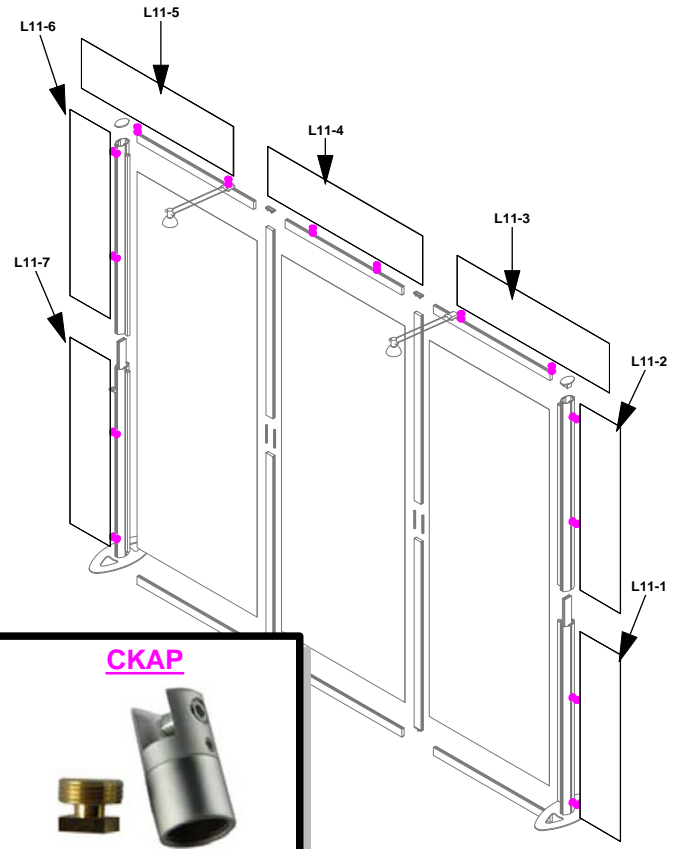
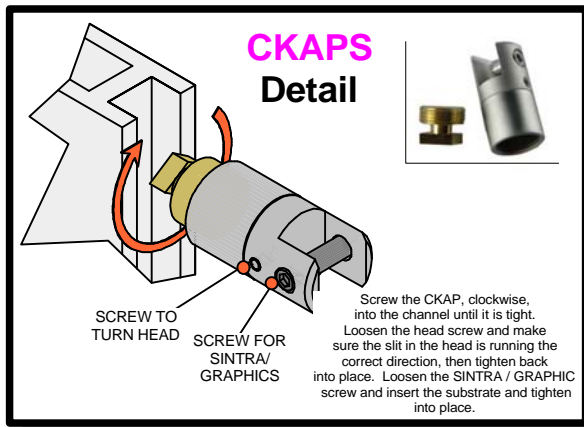

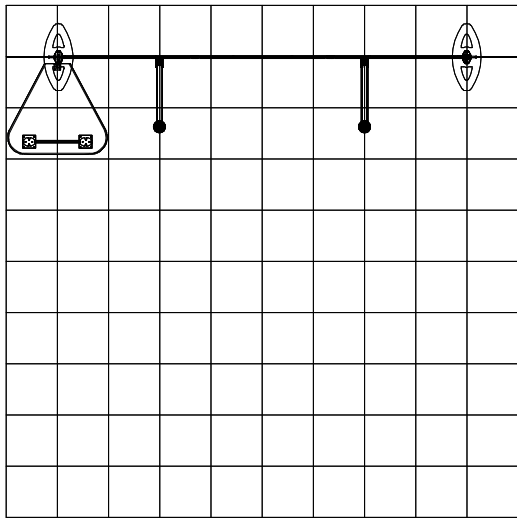

Code	#	Description
L10	1	TABLE TOP
L7	2	TABLE LEG
L8	1	TABLE SUPPORT

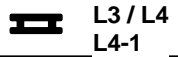
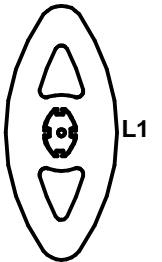
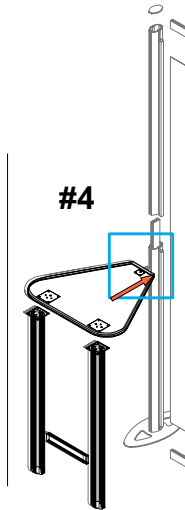
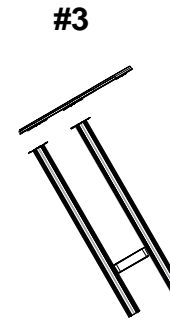
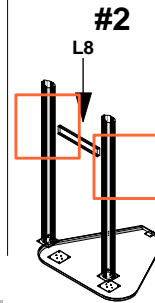
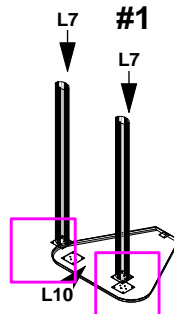

LINEAR

