

LINEAR 23

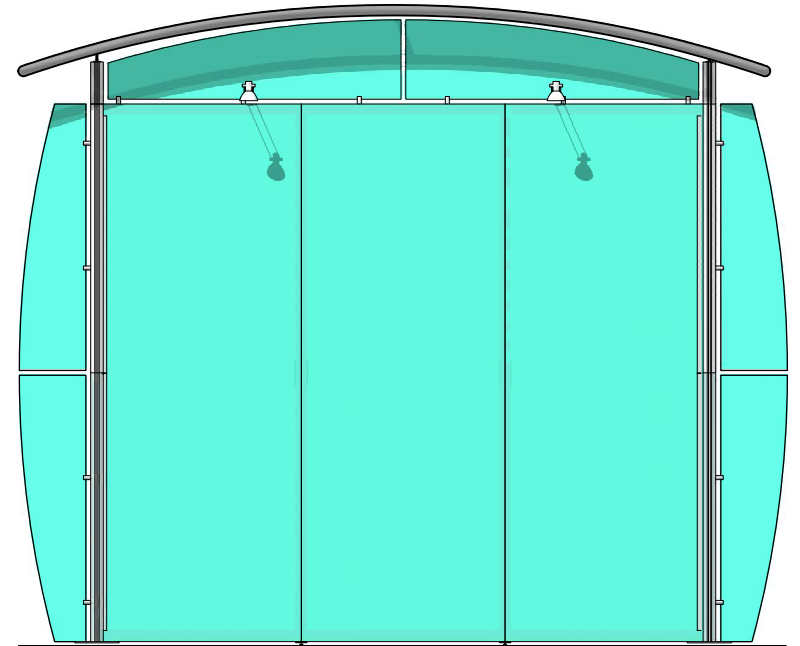

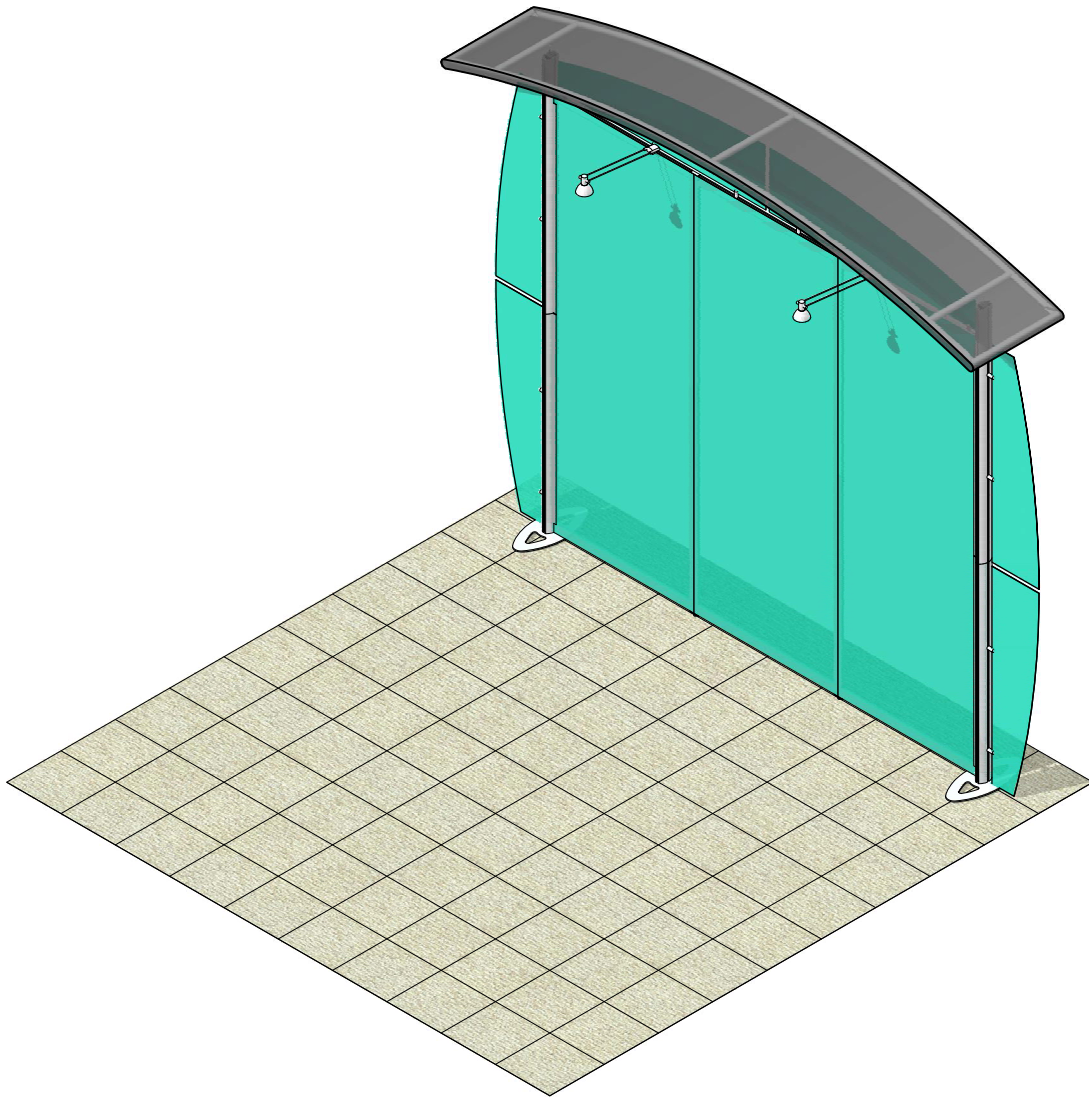

Code	#	Description
L3	3	HORIZONTAL GRAPHIC BAR
L4	2	VERTICAL GRAPHIC BAR WITH CENTER FOOT POST
L1	2	BOTTOM HALF UPRIGHT

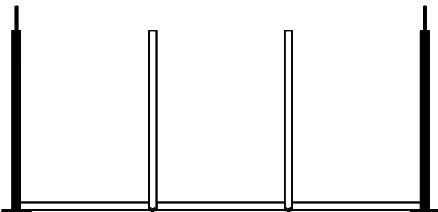
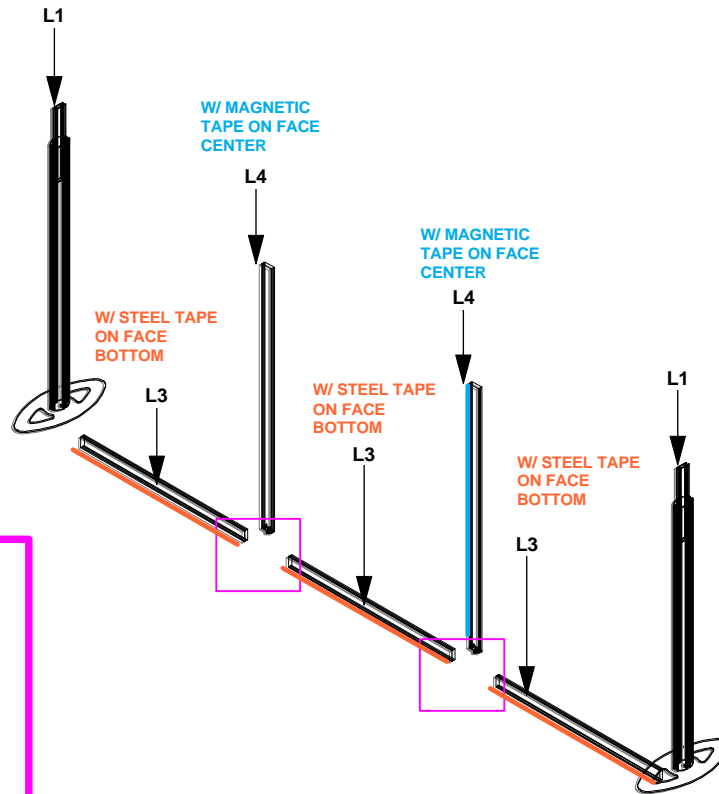
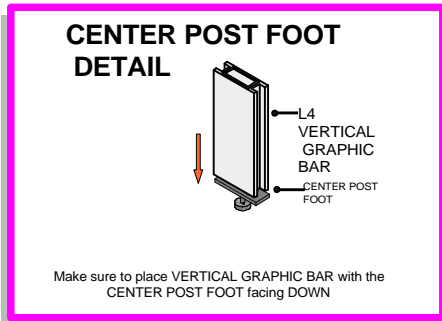
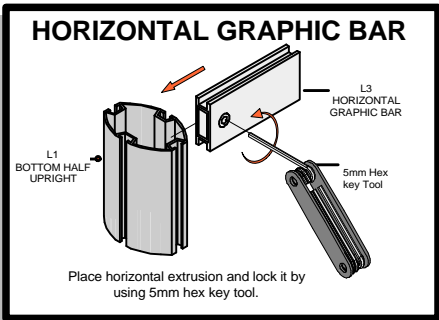
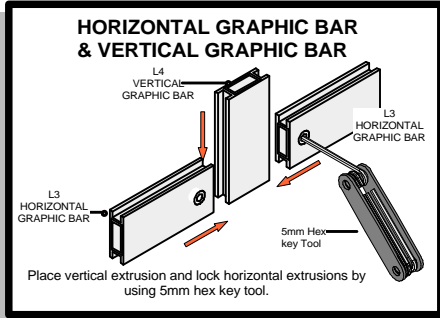
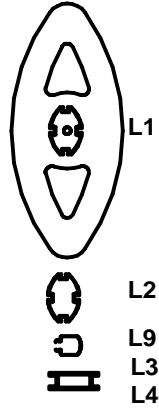

LINEAR 23



Code	#	Description
JOINER BAR	4	JOINER BAR

JOINER BAR DETAIL

SET SCREW

VERTICAL GRAPHIC BAR

Slide the JOINER BAR the tracks of one extrusion. Then push the two extrusions together.

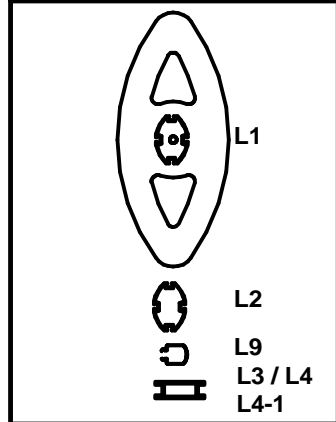
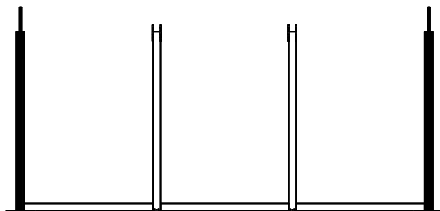
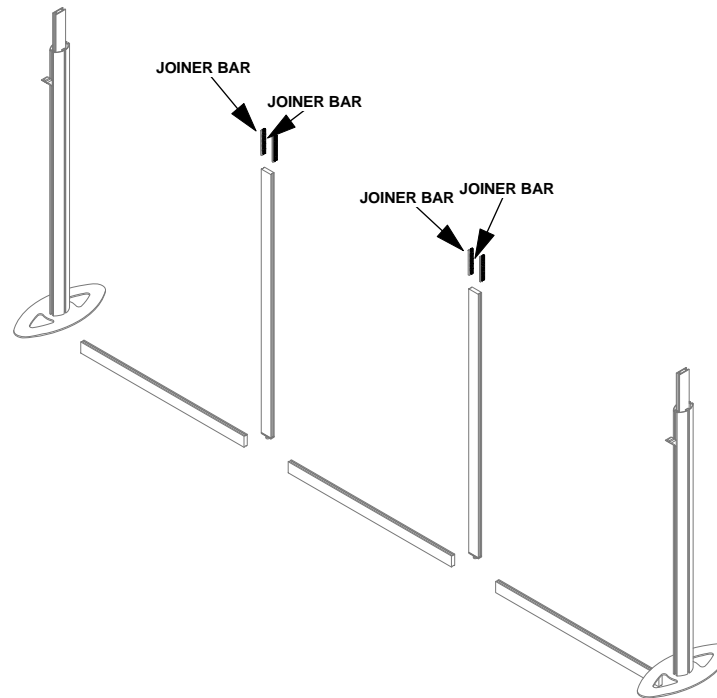

LINEAR 23



Code	#	Description
L2	2	TOP HALF UPRIGHT
L3	3	HORIZONTAL GRAPHIC BAR
L4-1	2	VERTICAL GRAPHIC BAR
L9	4	GRAPHICS MOUNTING BAR

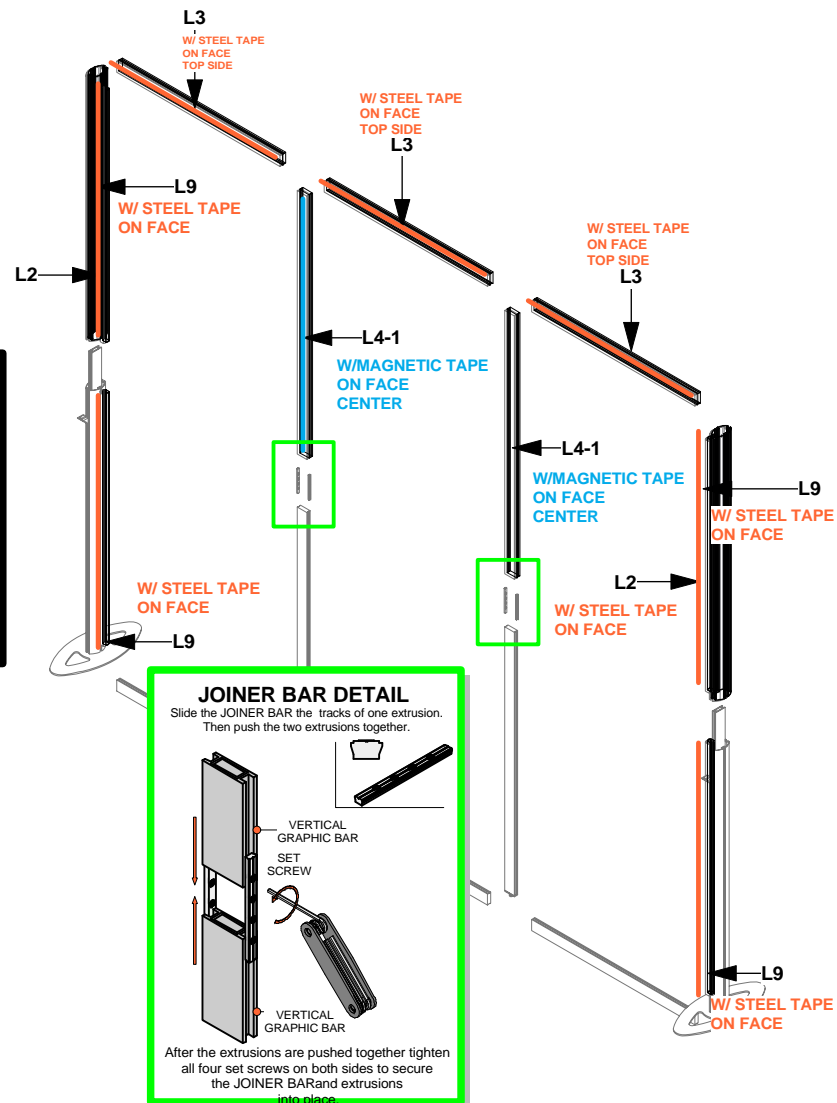
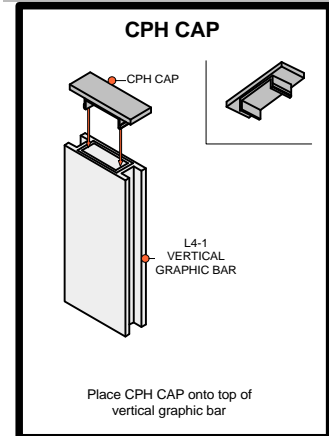
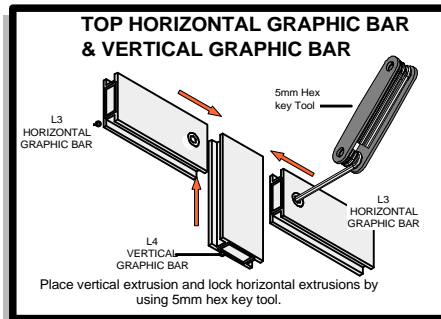
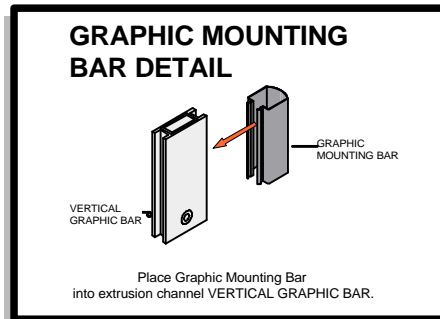
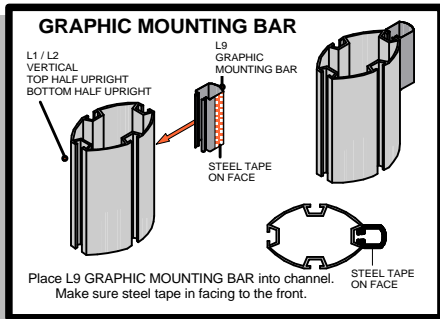
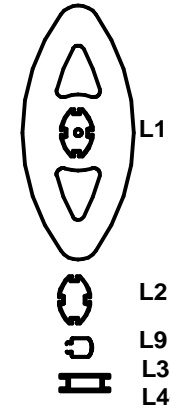

LINEAR 23

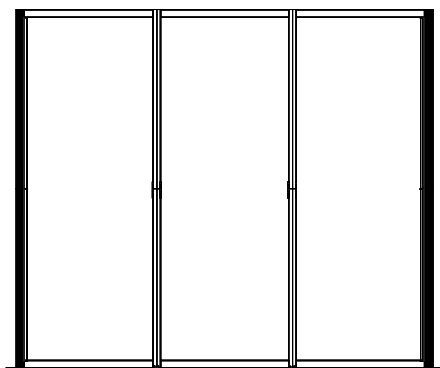
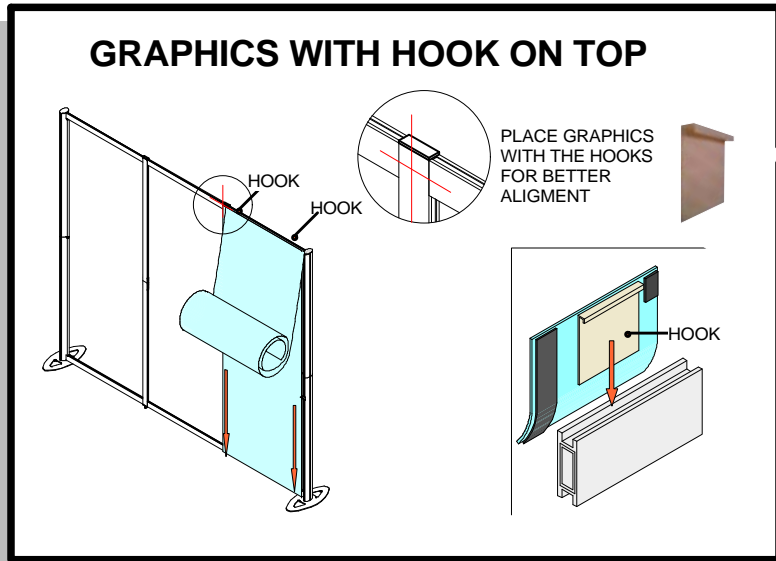

Code	#	Description
L5-2	1	GRAPHICS
L5-1	1	GRAPHICS
L5-3	1	GRAPHICS

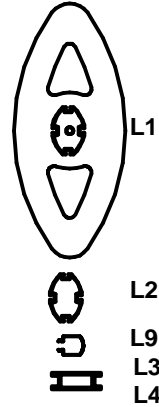
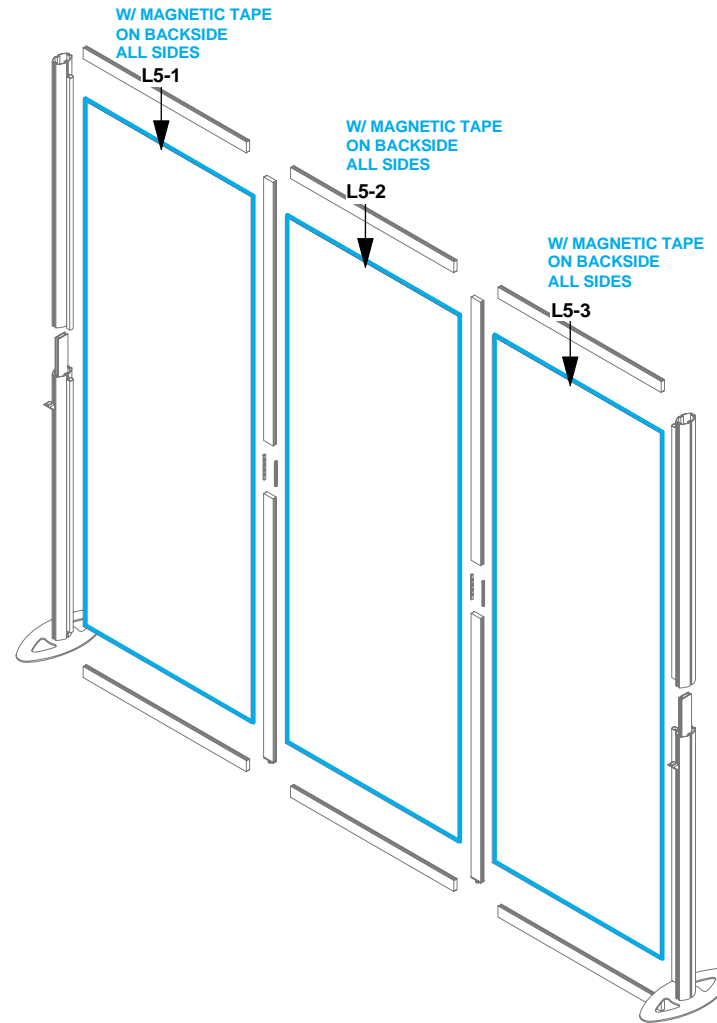

LINEAR 23

Code	#	Description
LV3 LIGHT	2	GREY SKINNY LIGHT WITH OSRAM TITAN 50W LA



LIGHT DETAIL

LIGHT CLIP
HORIZONTAL GRAPHIC BAR
L10 LIGHT
LV1 LIGHT
LV3 LIGHT
LIGHT CLIP

Slide the light clip into the channel at an angle and then gently lower down. Then slide the LV3 Light onto the light clip.

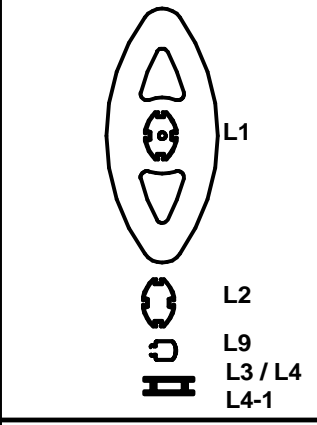
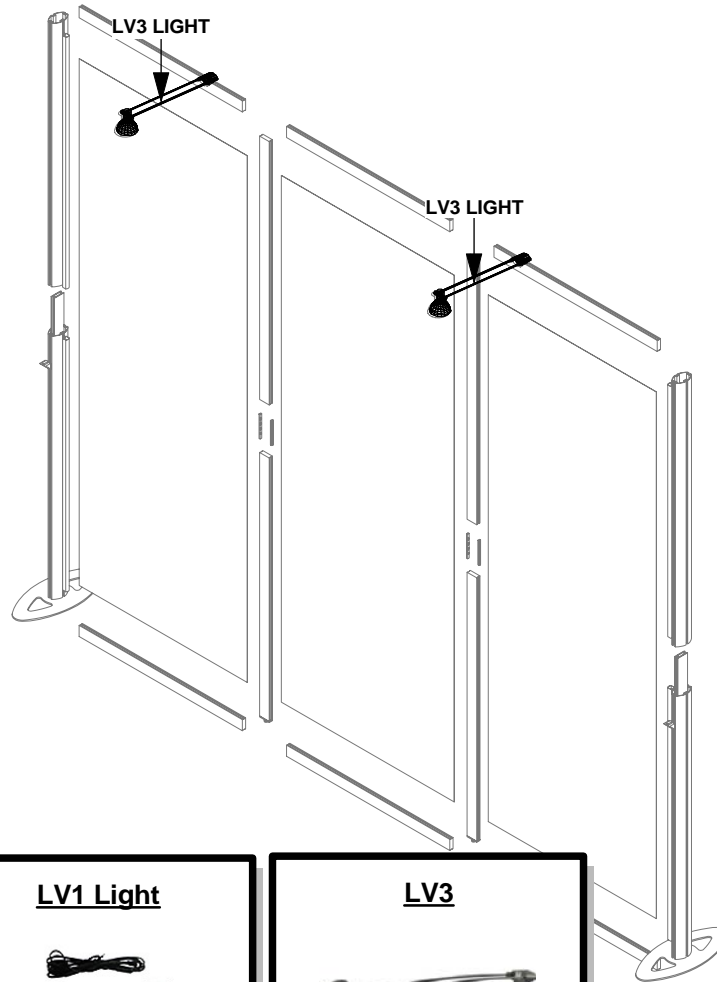

LINEAR 23

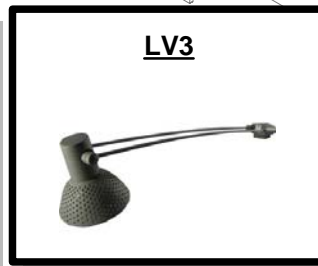
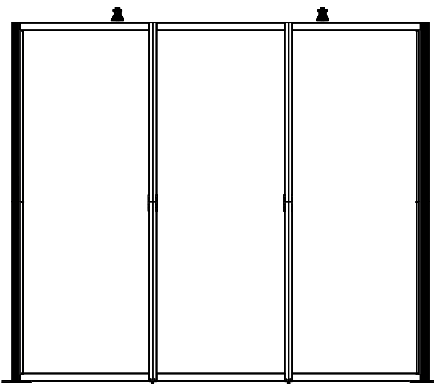

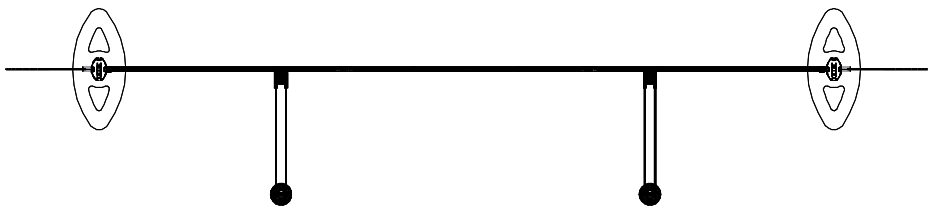

Code	#	Description
CKAPS	14	STANDOFFS
L11-4	1	GRAPHIC
L11-3	1	GRAPHIC
L11-2	1	GRAPHIC
L11-5	1	GRAPHIC
L11-1	1	GRAPHIC
L11-6	1	GRAPHIC

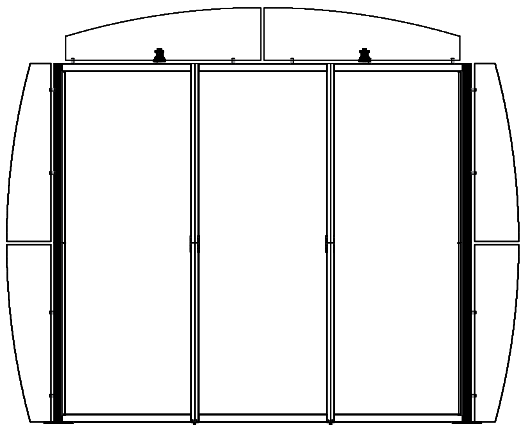
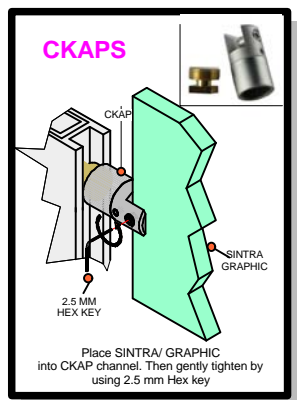
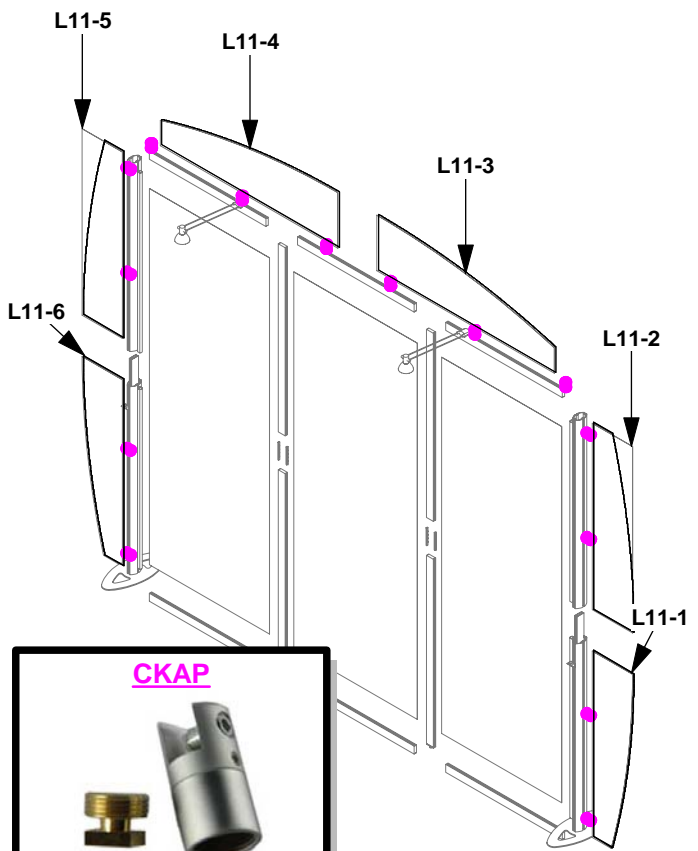
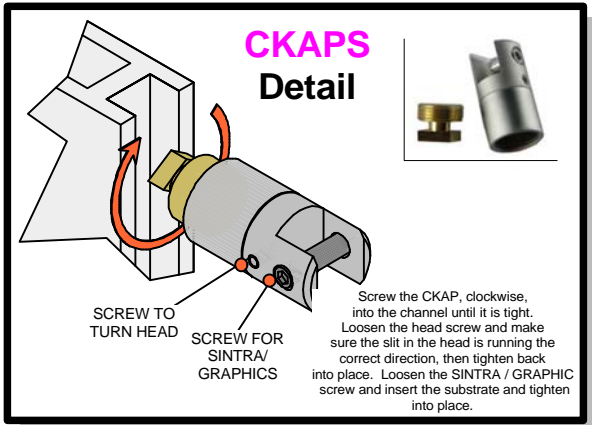
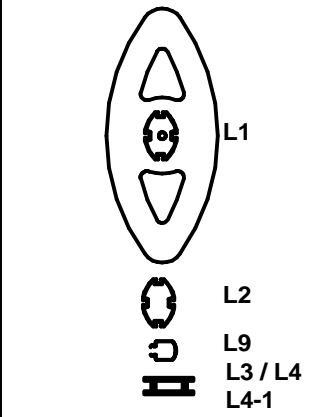

LINEAR 23

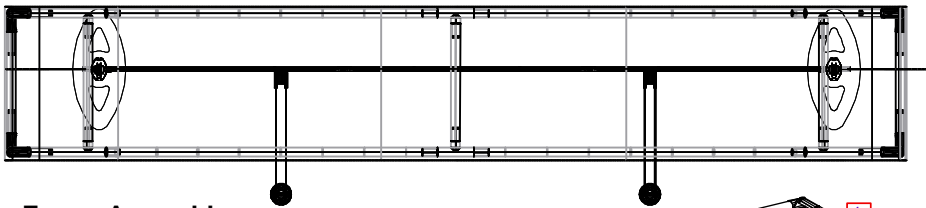

Frame Assembly

Assemble frame as shown

PART LIST:

PER UNIT
7 30MM DIA. TUBE SECTIONS

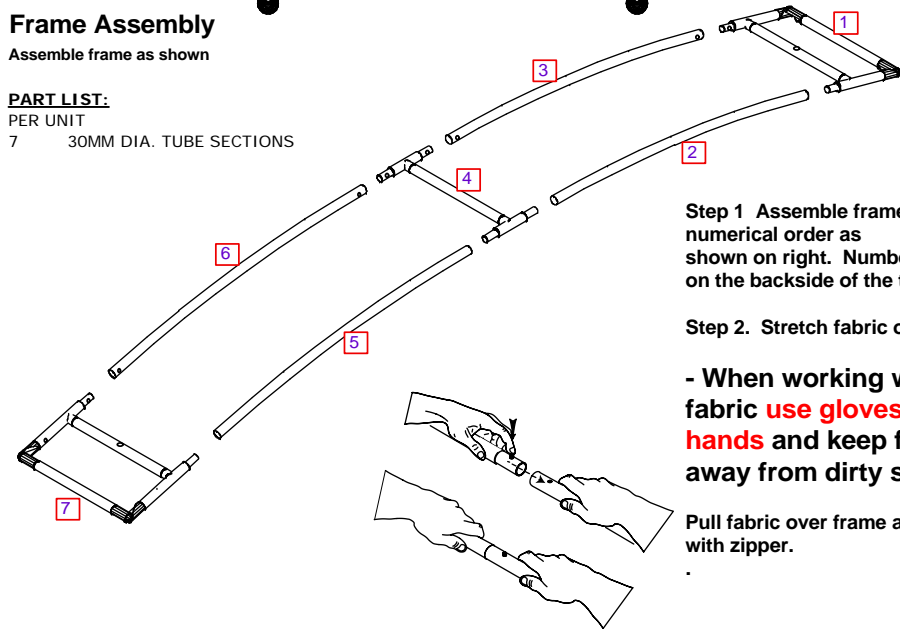

Step 1 Assemble frame in numerical order as shown on right. Numbers will be on the backside of the tube.

Step 2. Stretch fabric over frame.

- When working with fabric **use gloves or clean hands** and keep fabric away from dirty surfaces.

Pull fabric over frame and secure with zipper.

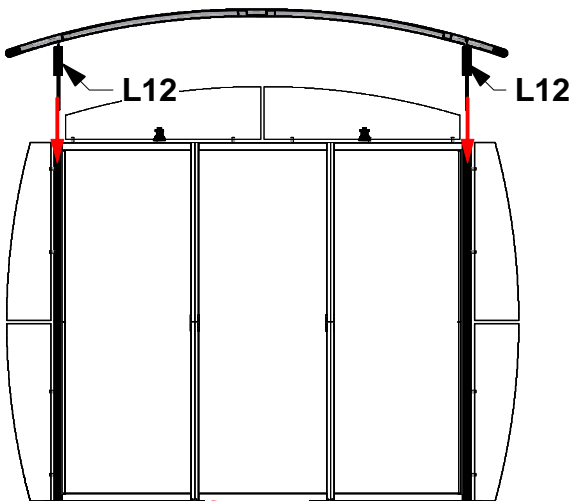

STEP # 3

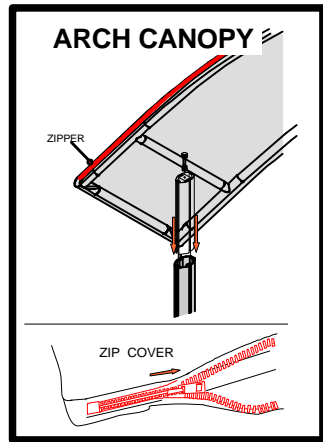

STEP # 2

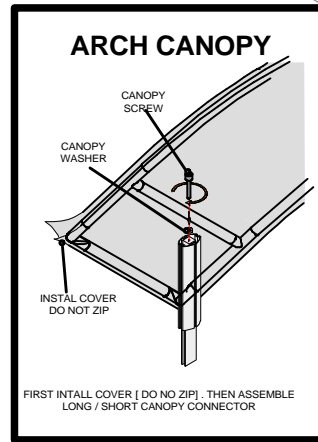

STEP #1

Code	#	Description
L12	2	SHORT CANOPY CONNECTOR
CANOPY SCREW	2	CANOPY SCREW
CANOPY WASHER	2	CANOPY WASHER
ARCH CANOPY	1	ARCH CANOPY

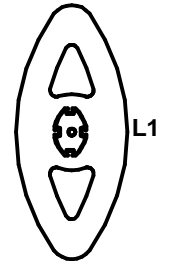
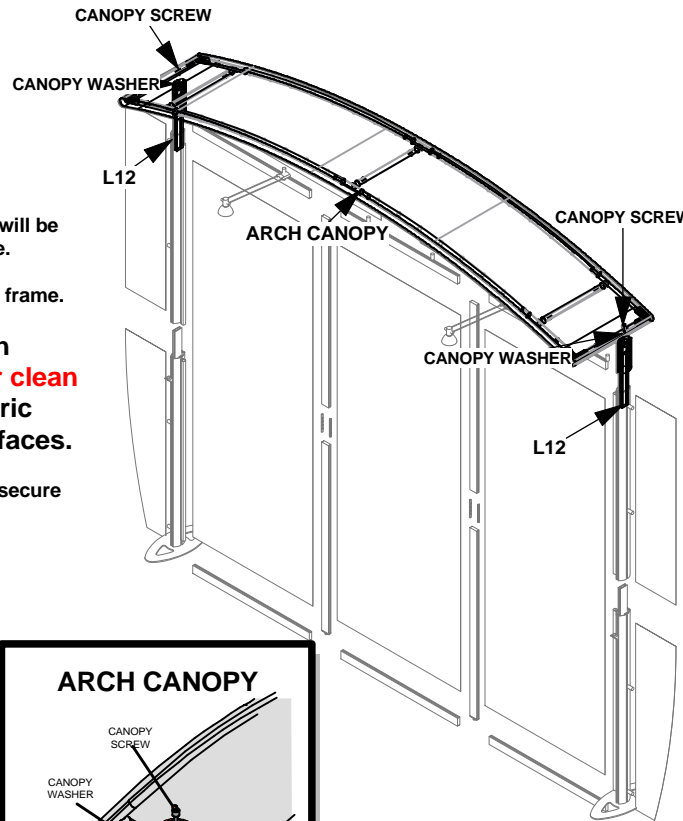

L1



L2



L9



L3 / L4



L4-1

LINEAR 23